

# JEE PHYSICS

- ▶ Specially designed eBook for complete JEE syllabus
- ▶ JEE preparation strategy & direction, speedy revision
- ▶ Chapter-wise important Problem-Solving
- ▶ Theory, Formulas & Diagrams to crack JEE
- ▶ Detailed high quality video lectures by experienced faculties
- ▶ JEE full preparation for Class XI & XII



**misostudy**  
connect smart learning

**JEE·NEET·AIIMS·CBSE·FOUNDATION**  
[www.misostudy.com](http://www.misostudy.com)

☎ 8929803804 (MON-FRI: 9am-6pm) [support@misostudy.com](mailto:support@misostudy.com)

MISO STUDY INDIA PVT. LTD.  
2ND FLOOR 65-A, OMPRO TOWER, KALU SARAI, NEW DELHI, DELHI 110016

**Class 12 | Physics**

# 01 Electrostatics-I

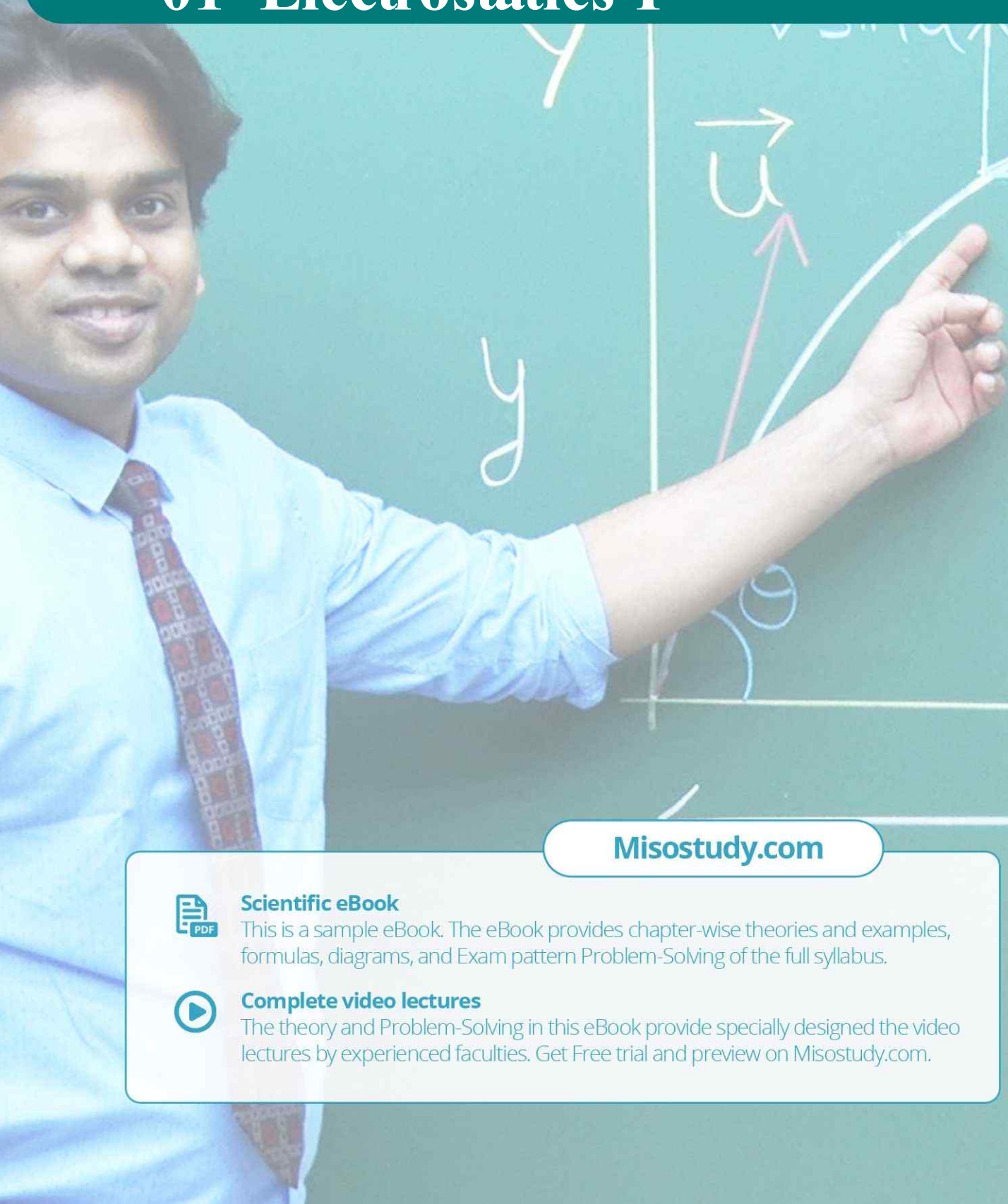

**Misostudy.com**



### **Scientific eBook**

This is a sample eBook. The eBook provides chapter-wise theories and examples, formulas, diagrams, and Exam pattern Problem-Solving of the full syllabus.



### **Complete video lectures**

The theory and Problem-Solving in this eBook provide specially designed the video lectures by experienced faculties. Get Free trial and preview on Misostudy.com.

## 01 Electrostatics-I

### 01. Introduction

Electrostatics, deals with the study of charges in rest. These stationary charges occurs due to friction of two insulating bodies, therefore it is often called frictional electricity.

#### Important points

- (i) Gravitational force is the weakest while nuclear force is the strongest force of the nature
- (ii) Nuclear force does not depend upon charge, it acts equally between proton-proton, proton neutron and neutron-neutron.
- (iii) There are weak forces acting in  $\beta$ -degradation in radio-activity.
- (iv) A stationary charge produces electric field while a moving charge produces electric as well as magnetic field.
- (v) Moving charge produces electric field as well as magnetic field but does not radiate energy while uniform acceleration.
- (vi) Accelerated charge produces electric field as well as magnetic field and radiates energy.

### 02. Charge

Property of a substance by virtue of which it can repel or attract another charged substance.

#### Charges are of two types

(a) **Positive charge** : Lesser number of electrons than number of protons.

(b) **Negative charge** : More number of electrons than number of protons

**Important Points** : Only, electron is responsible for a substance to be charged and not the proton.

#### Properties of Charge

- (i) Like charges repel while unlike charges attract each other.
- (ii) Charge is quantized in nature i.e. The magnitude of charge possessed by different objects is always an integral multiple of charge of electron (or proton) i.e.  $q = \pm ne$  where  $n = 1, 2, 3, \dots$
- (iii) The minimum possible charge that can exist in nature is the charge of electron which has a magnitude of  $e = 1.60207 \times 10^{-19}$  coulomb. This is also known as quantum of charge or fundamental charge.
- (iv) In an isolated system the algebraic sum of total charge remains constant. This is the law of 'Conservation of charge'.

### 03. Coulomb's Law

The force of attraction or repulsion between two stationary point charges is directly proportional to the product of charges and inversely proportional to the square of distance between them. This force acts along the line joining the two. If  $q_1$  &  $q_2$  are charges in consideration  $r$ , the distance between them and  $F$ , the force acting between them

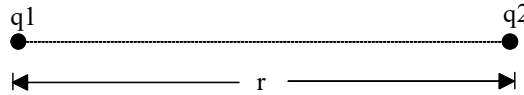

Then,  $F \propto q_1 q_2$

$$F \propto 1/r^2$$

$$\therefore F \propto \frac{q_1 q_2}{r^2}$$

$$\Rightarrow F = K \frac{q_1 q_2}{r^2}, \text{ where } k = \text{constant.}$$

$$K = \frac{1}{4\pi\epsilon_0\epsilon_r} = \frac{9 \times 10^9}{\epsilon_r} \text{ Nm}^2\text{C}^{-2}$$

where,

$\epsilon_0$  = Electric permittivity of vacuum or air

$$= 8.85 \times 10^{-12} \text{ C}^2\text{N}^{-1}\text{m}^{-2} \text{ and}$$

$K$  or  $\epsilon_r$  = Relative permittivity or Dielectric constant or Specific inductive capacity

$$\epsilon_r = \frac{\epsilon}{\epsilon_0} \Rightarrow \epsilon = \epsilon_0\epsilon_r$$

[Newton's law for particles is analogous to coulomb's law for rest charge. The difference is that Newton's law gives attraction force while coulomb's law gives attraction as well as repulsion force]

- NOTE** (i) Coulomb's law is applicable to point charges only. But it can be applied for distributed charges also
- (ii) This law is valid only for stationary charges and cannot be applied for moving charges.
- (iii) This law is valid only if the distance between two charges is not less than  $10^{-15}$  m

**Direction**

Direction of the force acting between two charges depends upon their nature and it is along the line joining two charges.

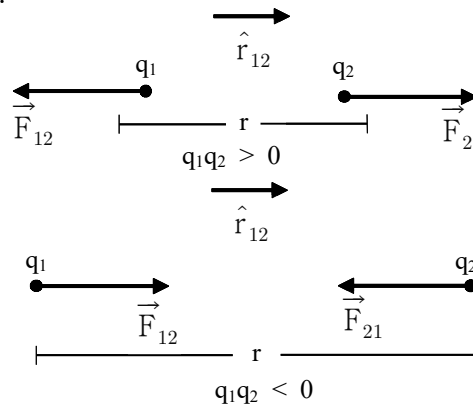

$\vec{F}_{21}$  = force on  $q_2$  due to  $q_1$

$$\vec{F}_{21} = \frac{q_1 q_2}{4\pi\epsilon_0\epsilon_r r_{12}^2} \hat{r}_{12} \quad \dots\dots(A)$$

(where  $\hat{r}_{12}$  is a unit vector pointing from  $q_1$  to  $q_2$ )

$\vec{F}_{12}$  = Force on  $q_1$  due to  $q_2$

$$\vec{F}_{12} = \frac{q_1 q_2}{4\pi\epsilon_0\epsilon_r r_{12}^2} \hat{r}_{21} \quad \dots\dots(B)$$

(where  $\hat{r}_{21}$  is a unit vector pointing from  $q_2$  to  $q_1$ )

⇒ Electric force between two charges not depends on neighbouring charges.

⇒ If a dielectric slab ( $\epsilon_r$ ) of thickness 't' is placed between two charges (distance d), force decreases.

$$F = \frac{Q_1 Q_2}{4\pi\epsilon_0 r^2} \quad \text{where } r = d - t + t\sqrt{\epsilon_r}$$

#### 04. Electric Field

A charge produces something called an electric field in the space around it and this electric field exerts a force on any charge placed in it.

**NOTE** The electric field does not exert force on source charge.

##### Electric field Intensity

Force experienced by a unit positive charge placed in an electric field at a point is called electric field intensity at that point. It is also known as electric field simply. Let  $q_0$  be the positive test charge placed in an electric field. If  $\vec{F}$  is the force experienced by this charge, then

$$\vec{E} = \lim_{q_0 \rightarrow 0} \frac{\vec{F}}{q_0}$$

- (i) Unit : N/C or volt/metre
- (ii) This is a vector quantity and its direction is the same as force on the positive test charge.

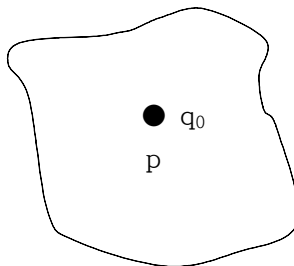

- (iii) Since  $\vec{E}$  is the force on unit charge, force on charge  $q$  is.  $\vec{F} = q\vec{E}$ .

- (iv) Dimension is  $[M^1L^1T^{-3}A^{-1}]$   
 (v) Electric field due to a point charge is

$$\vec{E} = \frac{kq}{r^2} \cdot \hat{r}$$

- (vi) Direction of electric field due to positive charge is away from charge while direction of electric field due to negative charge is towards the charge.

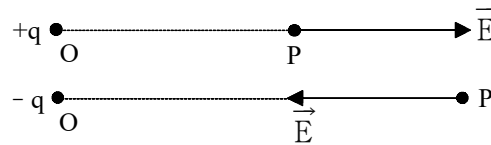

### Special point

- (a) If  $q_1$  and  $q_2$  are at a distance  $r$  and both have the same type of charge, then the distance 'd' of the point from  $q_1$  where electric field is zero is given by  $d = \frac{\sqrt{q_1} r}{(\sqrt{q_1} + \sqrt{q_2})}$ . This point will lie between line joining  $q_1$  &  $q_2$ .

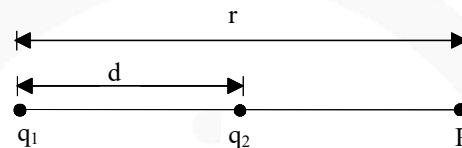

- (b) If  $q_1$  and  $q_2$  have opposite charges then distance 'd' of the point 'p' from  $q_1$  where electric field is zero is given by

$$d = \frac{\sqrt{q_1} r}{\sqrt{q_1} - \sqrt{q_2}}, \quad [|q_1| > |q_2|]$$

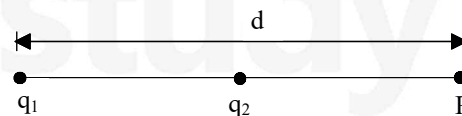

- (c) Three charges  $+Q_1$ ,  $+Q_2$  and  $q$  are placed on a straight line. If this system of charges is in equilibrium, charge  $q$  should be a given

$$q = \frac{Q_1 Q_2}{(\sqrt{Q_1} + \sqrt{Q_2})^2}$$

⇒ For measuring  $\vec{E}$  practically a test charge (+ve) of magnitude much less than the source charge should be used.

⇒ Electric force on a charge in uniform  $E$  is constant and hence acceleration is constant, so equations of motion can be used

$$\text{(acceleration } a = \frac{qE}{m}\text{)}$$

⇒ Electric field due to linear charge distribution (a) Finite wire

(d) Finite wire

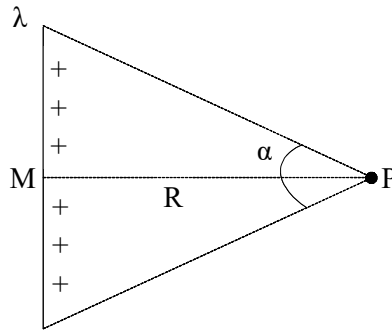

$$E_p = \frac{2k\lambda}{R} \sin \frac{\alpha}{2}$$

(e) Infinite wire ( $\alpha = 180^\circ$ )

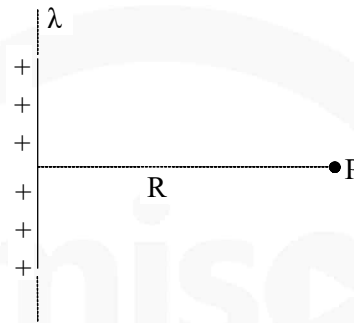

$$E_p = \frac{2k\lambda}{R}$$

(f) Charged arc

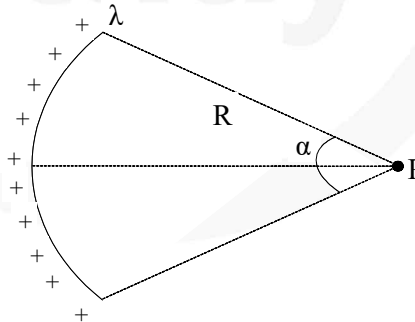

$$E_p = \frac{2k\lambda}{R} \sin \left( \frac{\alpha}{2} \right)$$

(g) Charged ring of radius R

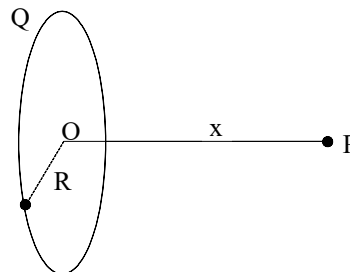

at and axial point  $E_p = \frac{kQx}{(R^2+x^2)^{3/2}}$ ;

$$x \gg R \Rightarrow E_p = \frac{kQ}{x^2}$$

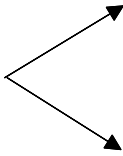
If 

$$x \ll R \Rightarrow E_p = \frac{kqx}{R^2}$$

As  $x$  is increases:  $\vec{E}$  due to ring first  $\uparrow$  then  $\downarrow$  and at  $X = \frac{R}{\sqrt{2}}$  it is maximum.

### Electric lines of forces : (ELF)

The electric field in a region can be represented by drawing certain curves known as electric lines of force.

An electric line of force is that imaginary smooth curve drawn in an electric field along which a free isolated unit positive charge moves.

#### Properties

- (i) Imaginary
- (ii) Can never cross each other
- (iii) Can never be closed loops
- (iv) The number of lines originating or terminating on a charge is proportional to the magnitude of charge. In rationalised MKS  $\left(\frac{1}{\epsilon_0}\right)$  system electric lines are associated with unit charge, so if a body encloses  $q$ , total lines of force associated with it (called flux) will be  $q/\epsilon_0$ .
- (v) Total lines of force may be fractional as lines of force are imaginary.

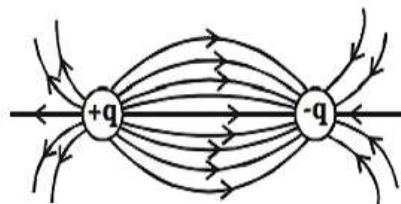

- (vi) Lines of force ends or starts normally at the surface of a conductor.
- (vii) If there is no electric field there will be no lines of force.
- (viii) Lines of force per unit area normal to the area at a point represents magnitude of intensity, crowded lines represent strong field while distant weak field.
- (ix) Tangent to the line of force at a point in an electric field gives the direction of intensity. So a positive charge free to move follow the line of force.



## 05. Electric Dipole

- (i) An system consisting of two equal and opposite charges separated by a small distance is termed and electric dipole.

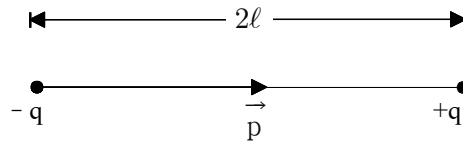

**Example :**  $\text{Na}^+\text{Cl}^-$ ,  $\text{H}^+\text{Cl}^-$  etc.

- (ii) An isolated atom is not a dipole because centre of positive charge coincides with centre of negative centres. But if atom is placed in an electric field, then the positive and negative centres are displaced relative to each other and atom become a dipole.
- (iii) **DIPOLE MOMENT:** The product of the magnitude of charges and distance between them is called the dipole moment.

It is denoted by  $\vec{p}$  and  $|\vec{p}| = q \times 2\ell$

- (a) This is a vector quantity which is directed from negative to positive charge.  
 (b) Unit : C-m  
 (c) Dimension :  $[M^0L^1T^1A^1]$

### Electric field due to a dipole

- (i) There are two components of electric field at any point
- (a)  $E_r \rightarrow$  in the direction of  $\vec{r}$   
 (b)  $E_\theta \rightarrow$  in the direction perpendicular to  $\vec{r}$

$$E_r = \frac{1}{4\pi\epsilon_0} \cdot \frac{2p \cos \theta}{r^3}$$

$$E_\theta = \frac{1}{4\pi\epsilon_0} \cdot \left( \frac{p \sin \theta}{r^3} \right)$$

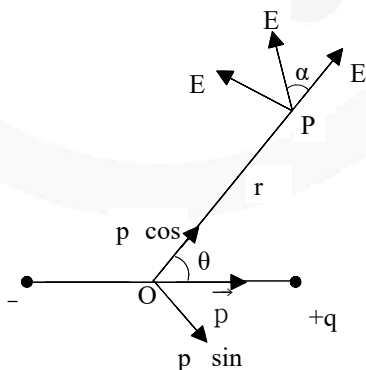

- (i) Resultant

$$E = \sqrt{E_r^2 + E_\theta^2} = \frac{p}{4\pi\epsilon_0 r^3} \sqrt{1 + 3\cos^2 \theta}$$

- (ii) Angle between the resultant  $\vec{E}$  and  $\vec{r}$ ,  $\alpha$  given

$$\text{by } \alpha = \tan^{-1} \left( \frac{E_\theta}{E_r} \right) = \tan^{-1} \left( \frac{1}{2} \tan \theta \right)$$

(iii) If  $\theta = 0$ , i.e point is on the axis -

$$E_{\text{axis}} = \frac{2kp}{r^3} \quad (r \gg \ell)$$

(iv) If  $\theta = 90^\circ$ , i.e. point is on the line bisecting the dipole perpendicularly

$$E_{\text{equatorial}} = \frac{kp}{r^3} \quad (r \gg \ell)$$

(v) So,  $E_{\text{axis}} = 2E_{\text{equatorial}}$  (for same r)

$$(vi) \quad E_{\text{axis}} = \frac{1}{4\pi\epsilon_0} \cdot \frac{2pr}{(r^2 - \ell^2)^2}$$

$$E_{\text{equatorial}} = \frac{1}{4\pi\epsilon_0} \cdot \frac{p}{(r^2 + \ell^2)^{3/2}}$$

where  $p = q \cdot (2\ell)$

(vii)

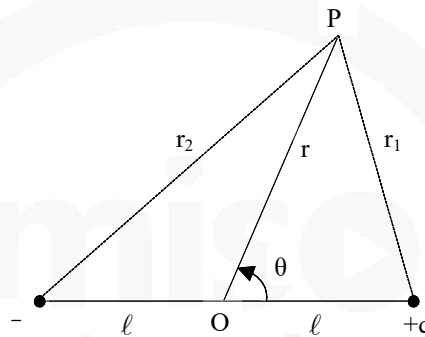

potential at a general point.

$$V = \frac{1}{4\pi\epsilon_0} \frac{p \cos \theta}{r^2}$$

(viii) If  $\theta = 0^\circ$ ,  $V_{\text{axis}} = \frac{kp}{r^2}$

(ix) If  $\theta = 90^\circ$ ,  $V_{\text{equator}} = 0$

(x) Here we see that  $V = 0$  but  $E \neq 0$  for points at equatorial position.

(xi) Again, if  $r \gg d$  is not true and  $d = 2\ell$ ,

$$V_{\text{axis}} = \frac{1}{4\pi\epsilon_0} \cdot \frac{p}{(r^2 - \ell^2)}$$

$$V_{\text{equator}} = 0$$

- NOTE**
- (i) This is not essential that at a point, where  $E = 0$ ,  $V$  will also be zero there eg. inside a uniformly charged sphere,  $E = 0$  but  $V \neq 0$
  - (ii) Also if  $V = 0$ , it is not essential for  $E$  to be zero eg. in equatorial position of dipole  $V = 0$ , but  $E \neq 0$

### Electric Dipole In an Electric Field – Uniform Electric Field

(i) When an electric dipole is placed in a uniform electric field, A torque acts on it which subjects the dipole to rotatory motion. This  $\tau$  is given by  $\tau = pE \sin\theta$  or  $\vec{\tau} = \vec{p} \times \vec{E}$

(ii) Potential energy of the dipole

$$U = -pE \cos\theta = -\vec{p} \cdot \vec{E}$$

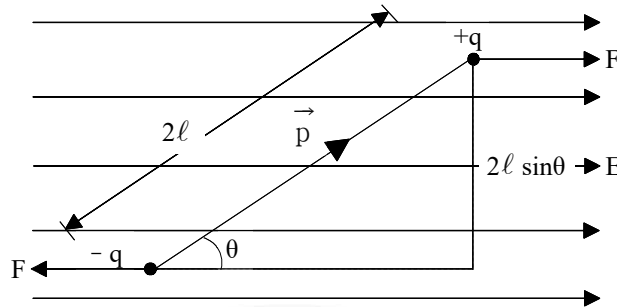

#### Cases

- If  $\theta = 0^\circ$ , i.e.  $\vec{p} \parallel \vec{E}$ ,  $\tau = 0$  and  $U = -pE$ , dipole is in the minimum potential energy state and no torque acting on it and hence it is in the stable equilibrium state.
- For  $\theta = 180^\circ$ , i.e.  $\vec{p}$  and  $\vec{E}$  are in opposite direction, then  $\tau = 0$  but  $U = pE$  which is maximum potential energy state. Although it is in equilibrium but it is not a stable state and a slight perturbation can disturb it.
- $\theta = 90^\circ$ , i.e.  $\vec{p} \perp \vec{E}$ , then  $\tau = pE$  (maximum) and  $U = 0$

#### Work done in rotating an electric dipole in and electric field

- To rotate the dipole by an angle  $\theta$  from the state of stable equilibrium  $W = pE(1 - \cos\theta)$ .
- Work done in rotating the dipole from  $\theta_1$  to  $\theta_2$  in an uniform electric field  $W = pE(\cos\theta_1 - \cos\theta_2)$
- Work done in rotating the dipole through  $180^\circ$  from stable equilibrium state  $W = 2pE = 2$  (potential energy)

## 06. Electric Flux

- It is denoted by ' $\phi$ '.
- It is a scalar quantity.
- It is defined as the total number of lines of force passing normally through a curved surface placed in the field.
- It is given by the dot product of  $\vec{E}$  and normal infinitesimal  $\vec{ds}$  area integrated over a closed surface.

$$d\phi = \vec{E} \cdot \vec{ds}$$

$$\phi = \oint \vec{E} \cdot \vec{ds} = \oint E ds \cos\theta$$

where  $\theta$  = angle between electric field and normal to the area

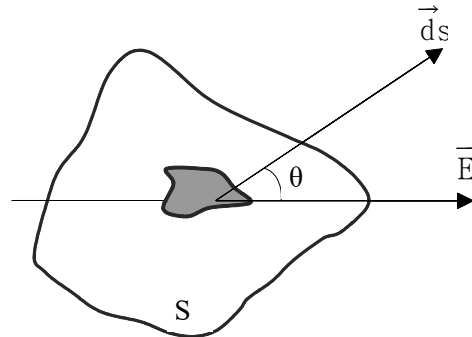

- (v) Unit : (a)  $\text{N}\cdot\text{m}^2/\text{C}$  (b) volt – meter
- (vi) Dimension :  $[\text{ML}^3\text{T}^{-3}\text{A}^{-1}]$
- (vii) Flux due to a positive charge goes out of the surface while that due to negative charge comes into the surface.
- (viii) Value of electric flux is independent of shape and size of the surface.
- (ix) If only a dipole is present in the surface then net flux is zero.
- (x) Net flux from a surface is zero does not imply that intensity of electric field is also zero.

## 07. Gauss's Law

This law states that electric flux  $\phi_E$  through any closed surface is equal to  $1/\epsilon_0$  times the net charge 'q' enclosed by the surface i.e

$$\phi_E = \oint \vec{E} \cdot \vec{ds} = \frac{q}{\epsilon_0}$$

### Important point about flux

- Independent of distances between charges inside the surface and their distribution.
- Independent of shape, size and nature of surface.
- Net flux due to a charge outside the surface will be zero.
- Gauss law is valid only for the vector fields which obey inverse square law

### Example

A hemispherical surface of radius R is kept in a uniform electric field E such that E is parallel to the axis of hemi-sphere, Net flux from the surface will be

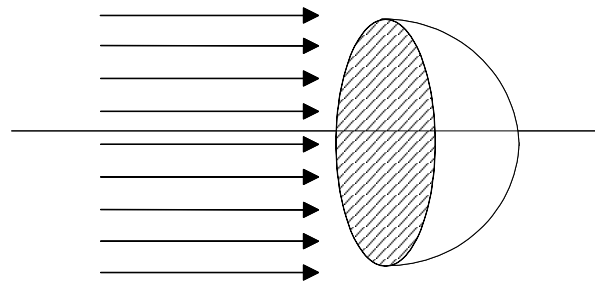

### Solution

$$\begin{aligned} \phi &= \oint \vec{E} \cdot \vec{ds} = E \cdot \pi R^2 \\ &= (E) (\text{Area of surface perpendicular to } E) \\ &= E \cdot \pi R^2. \end{aligned}$$

## 08. Application of Gauss's Law

Electric field due to a solid conducting sphere/Hollow conducting sphere.

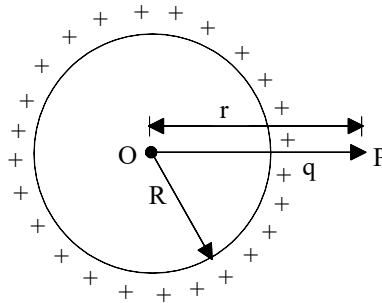

(i) **Case: 1**  $r > R$        $\vec{E} = \frac{kq}{r^2} \hat{r} = \frac{1}{\epsilon_0} \frac{\sigma R^2}{r^2} \hat{r}$

**Case: 2**  $r = R$        $\vec{E} = \frac{\sigma}{\epsilon_0} \hat{r}$

**Case: 3**  $r < R$        $\vec{E} = 0$

i.e. At point interior to a conducting or a hollow sphere, electric field intensity is zero.

- (ii) For points outside the sphere, it behaves like all the charge is present at the centre.  
(iii) Intensity of electric field is maximum at the surface

### Imp.

- (iv) Electric field at the surface is always perpendicular to the surface.  
(v) For points, near the surface of the conductor,  $E = \frac{\sigma}{\epsilon_0}$  perpendicular to the surface

### Electric field due to infinitely long charge

- (i) A long wire is given a line charge density  $\lambda$ . If wire is positively charged, direction of  $\vec{E}$  will be away from the wire (outward  $\perp$ ) while for a negatively charged wire, direction of  $\vec{E}$  will be (inward  $\perp$ ) towards the wire.  
(ii) E at point p

$$\vec{E} = \frac{\lambda}{2\pi\epsilon_0 r} \hat{r} \quad \text{or} \quad E = \frac{\lambda}{2\pi\epsilon_0 r}$$

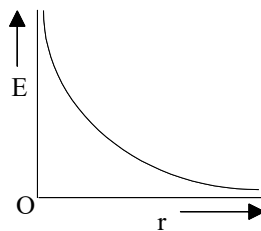

- (iii) Potential difference between points A ( $r_1$ ) & B ( $r_2$ ) =  $V_2 - V_B = \frac{\lambda}{2\pi\epsilon_0} \ln \left( \frac{r_2}{r_1} \right)$   
(iv) Potential difference between points A ( $r_1$ ) & B ( $r_2$ ) =  $V_2 - V_B = \frac{\lambda}{2\pi\epsilon_0} \ln \left( \frac{r_2}{r_1} \right)$

### Electric field at a point due to an infinite sheet of charge

- (i) If  $\sigma$  = surface charge density. Intensity at points near to the sheet  $\vec{E} = \frac{\sigma}{2\epsilon_0} \hat{r}$

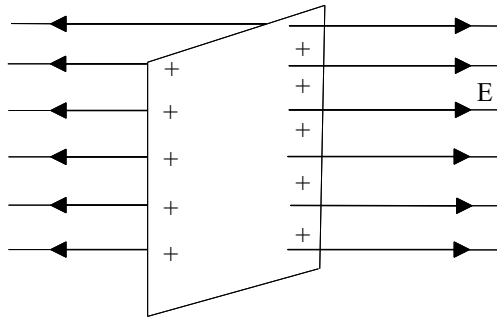

- (ii) Direction of electric field is perpendicular to the sheet of charge.  
 (iii) Intensity of electric field does not depend upon the distance of points from the sheet for the points in front of sheet i.e. There is an equipotential region near the charged sheet.  
 (iv) Potential difference between two points A & B at distances  $r_1$  &  $r_2$  respectively is

$$V_A - V_B = \frac{\sigma}{2\epsilon_0} (r_2 - r_1)$$

### Electric field due to infinite charged metal plate

- (i) Intensity at points near the plate  $\vec{E} = \frac{\sigma}{\epsilon_0} \hat{r}$

where  $\sigma$  = surface charge density

- (ii)  $\vec{E}$  is independent of distance of the point from the plate and also of the area of sheet i.e. There is an equipotential region near the plate.

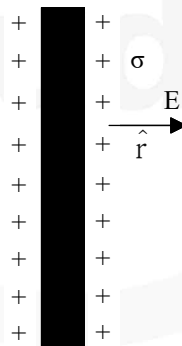

- (iii) Direction of electric field is perpendicular to the plate.  
 (iv) Potential difference between two point A ( $r_1$ ) and B ( $r_2$ ) ( $r_1 < r_2$ ) near the plate is

$$\Delta V = V_A - V_B = \frac{\sigma}{\epsilon_0} (r_2 - r_1)$$

### Electric field due to charged ring : Q charge is distributed over a ring of radius R.

- (i) Intensity of electric field at a distance x from the centre of ring along it's axis-

$$E = \frac{1}{4\pi\epsilon_0} \frac{Q \cos\theta}{r^2} = \frac{Qx}{4\pi\epsilon_0 r^3} \quad (\because \cos\theta = x/r)$$

$$= \frac{1}{4\pi\epsilon_0} \frac{Qx}{(R^2 + x^2)^{3/2}} \quad [\because r = \sqrt{R^2 + x^2}]$$

and it's direction will be along the axis of the ring.

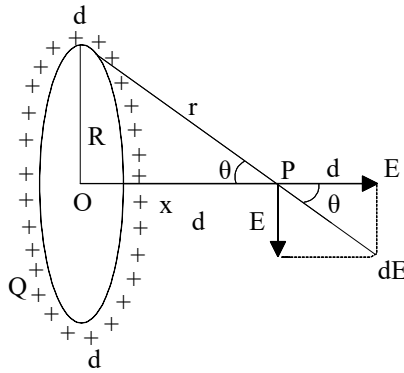

- (ii) Intensity will be zero at the centre of the ring.  
 (iii) Intensity will be maximum at a distance  $R/\sqrt{2}$  from the centre and

$$E_{\max} = \frac{2}{3\sqrt{3}} \cdot \frac{1}{4\pi\epsilon_0} \cdot \frac{Q}{R^2}$$

- (iv) Electric potential at a distance  $x$  from centre,

$$V = \frac{1}{4\pi\epsilon_0} \frac{Q}{\sqrt{(x^2 + R^2)}}$$

miso  
study

## JEE Main Pattern Exercise (1)

1. A particle of charges  $Q$  and mass  $m$  travels through a potential difference  $V$  from rest. The final momentum of the particle is

- (a)  $\frac{mv}{Q}$  (c)  $\sqrt{2mQV}$   
(b)  $2Q\sqrt{mV}$  (d)  $\sqrt{\frac{2QV}{m}}$

2. Three concentric conducting spherical shells carry charges as follows  $+4Q$  on the inner shell,  $-2Q$  on the middle shell and  $-5Q$  on the outer shell. The charge on the inner surface of the outer shell is

- (a) 0 (c)  $-Q$   
(b)  $4Q$  (d)  $-2Q$

3. The work done against electric forces in increasing the potential difference of a condenser from 20V to 40V is  $W$ . The work done in increasing its potential difference from 40V to 50 V will be

- (a)  $4W$  (c)  $2W$   
(b)  $\frac{3W}{4}$  (d)  $\frac{W}{2}$

4. The plate separation in a parallel plate condenser is  $d$  and plate area is  $A$ . If it is charged to  $V$  volt and battery is disconnected then the work done in increasing the plate separation to  $2d$  will be

- (a)  $\frac{3}{2} \frac{\epsilon_0 A V^2}{d}$  (c)  $\frac{2\epsilon_0 A V^2}{d}$   
(b)  $\frac{\epsilon_0 A V^2}{d}$  (d)  $\frac{\epsilon_0 A V^2}{2d}$

5. A parallel plate condenser is connected to a battery of e.m.f. 4 volt. If a plate of dielectric constant 8 is inserted into it, then the potential difference on the condenser will be

- (a) 0.5V (c) 4V  
(b) 2V (d) 32V



## 01 Electrostatics-I

6. A solid sphere of radius  $R$  is charged uniformly. At what distance from its surface is the electrostatic potential half of the potential at the centre?
- (a)  $R$  (c)  $R/3$   
(b)  $R/2$  (d)  $2R$
7. A particle of charge  $1 \mu\text{C}$  and mass  $1 \text{ gm}$  moving with a velocity of  $4 \text{ m/s}$  is subjected to a uniform electric field of magnitude  $300 \text{ V/m}$  for  $10\text{s}$ . Its final speed cannot be
- (a)  $0.5 \text{ m/s}$  (c)  $3 \text{ m/s}$   
(b)  $4 \text{ m/s}$  (d)  $6 \text{ m/s}$
8. Electric field on the axis of a small electric dipole at a distance  $r$  is  $\vec{E}_1$  and  $\vec{E}_2$  at a distance of  $2r$  on a line of perpendicular bisector. Then
- (a)  $\vec{E}_2 = -\vec{E}_{1/8}$  (c)  $\vec{E}_2 = -\vec{E}_{1/4}$   
(b)  $\vec{E}_2 = -\vec{E}_{1/16}$  (d)  $\vec{E}_2 = \vec{E}_{1/8}$
9. An electric field is given by  $\vec{E} = (y\hat{i} + x\hat{j})\text{N/C}$ . The work done in moving a  $1\text{C}$  charge from  $\vec{r}_A = (2\hat{i} + 2\hat{j})\text{m}$  to  $\vec{r}_B = (4\hat{i} + \hat{j})\text{m}$  is
- (a)  $+ 4 \text{ J}$  (c)  $+ 8 \text{ J}$   
(b)  $- 4 \text{ J}$  (d) zero
10. A hollow metal sphere of radius  $5 \text{ cm}$  is charged such that the potential on its surface is  $10 \text{ V}$ . The potential at the centre of the sphere is
- (a) zero  
(b)  $10 \text{ V}$   
(c) same as at a point  $5 \text{ cm}$  away from the surface  
(d) same as at a point  $25 \text{ cm}$  away from the surface

## JEE Advanced Pattern Exercise (1)

### (Q1 & 2) Only One Correct Option

- The potential field of an electric field  $\vec{E} = (y\hat{i} + x\hat{j})$  is
  - $V = -xy + \text{constant}$
  - $V = -(x + y) + \text{constant}$
  - $V = -(x^2 + y^2) + \text{constant}$
  - $V = \text{constant}$
- Capacity of an isolated sphere is increased  $n$  times when it is enclosed by an earthed concentric sphere. The ratio of their radii is
 

<ol style="list-style-type: none"> <li><math>\frac{n^2}{n-1}</math></li> <li><math>\frac{n}{n-1}</math></li> </ol>	<ol style="list-style-type: none"> <li><math>\frac{2n}{n+1}</math></li> <li><math>\frac{2n+1}{n+1}</math></li> </ol>
--	--

### (Q3) More than One Correct Option

- Figure shows some of the electric field lines corresponding to an electric field. The figure suggests that ( $E =$  electric field,  $V =$  potential)

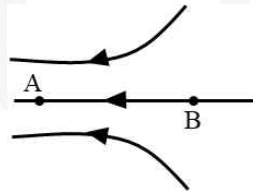

- |  |  |
|--|--|
| <ol style="list-style-type: none"> <li><math>E_A &gt; E_B</math></li> <li><math>E_A &lt; E_B</math></li> </ol> | <ol style="list-style-type: none"> <li><math>V_A &gt; V_B</math></li> <li><math>V_A &lt; V_B</math></li> </ol> |
|--|--|

### (Q4 to 5) Comprehension Type

#### Passage

A charge  $q = (-2 \times 10^{-9})$  C is placed at  $(1\text{m}, 2\text{m}, 3\text{m})$ . There is a point  $P = (2\text{m}, -3\text{m}, 4\text{m})$

- A unit vector in the direction of electric field at  $P$  due to charge  $q$  will be

- |   |   |
|---|---|
| <ol style="list-style-type: none"> <li><math>\frac{1}{3\sqrt{3}}(\hat{i} - 5\hat{j} + \hat{k})</math></li> <li><math>\frac{1}{3\sqrt{3}}(-\hat{i} + 5\hat{j} - \hat{k})</math></li> </ol> | <ol style="list-style-type: none"> <li><math>\frac{1}{5\sqrt{2}}(3\hat{i} + 4\hat{j} - 5\hat{k})</math></li> <li><math>\frac{1}{5\sqrt{2}}(-3\hat{i} + 4\hat{j} - 5\hat{k})</math></li> </ol> |
|---|---|

5. Component of electric field along  $x$ -axis at point  $P$  would be

- (a)  $\frac{1}{5\sqrt{3}}$  N/C (c)  $\frac{2}{9\sqrt{3}}$  N/C  
 (b)  $\frac{9}{5\sqrt{3}}$  N/C (d)  $8\sqrt{3}$  N/C

**(Q6 & 7) Only One Correct Option**

6. A spherical charged conductor has surface charge density  $\sigma$ . The electric field on its surface is  $E$  and electric potential of conductor is  $V$ . Now the radius of the sphere is halved keeping the charge to be constant. The new values of electric field and potential would be

- (a)  $2E, 2V$  (c)  $4E, 4V$   
 (b)  $4E, 2V$  (d)  $2E, 4V$

7. Two concentric spherical conducting shells of radii  $R$  and  $2R$  carry charges  $Q$  and  $2Q$  respectively. Change in electric potential on the outer shell when both are connected by a conducting wire is  $\left(k = \frac{1}{4\pi\epsilon_0}\right)$

- (a) zero (c)  $\frac{kQ}{R}$   
 (b)  $\frac{3kQ}{2R}$  (d)  $\frac{2kQ}{R}$

**(Q8) More than One Correct Option**

8. A circular ring carries a uniformly distributed positive charge. The electric field ( $E$ ) and potential ( $V$ ) varies with distance ( $r$ ) from the centre of the ring along its axis as

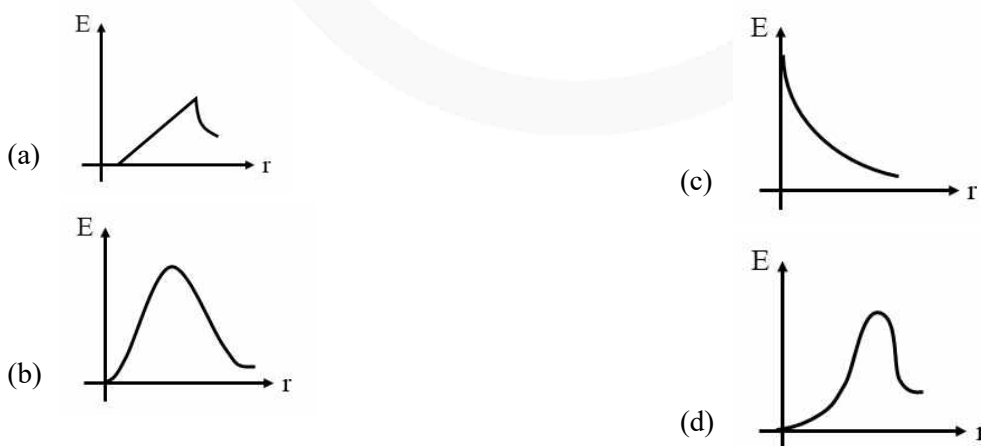

**(Q9) Matrix Match Type**

9. In the figure shown,  $P$  is a point on the surface of an imaginary sphere. Match the following.

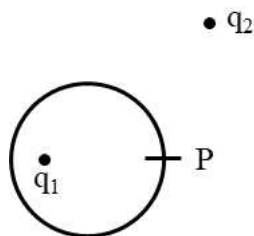

Table-1	Table-2
(a) Electric field at point $P$	(p) due to $q_1$ only
(b) Electric flux through a small area at $P$	(q) due to $q_2$ only
(c) Net electric flux through whole sphere	(r) due to both $q_1$ and $q_2$

**(Q10) Integer Type**

10. The centers of two identical small conducting spheres are 1 m apart. They carry charges of opposite kind and attract each other with a force  $F$ . When they are connected by conducting thin wire they repel each other with a force  $F/3$ . The ratio of magnitude of charges carried by the spheres initially is  $n : 1$ . Find value of  $n$ .

# JEE

# CHEMISTRY

- ▶ Specially designed eBook for complete JEE syllabus
- ▶ JEE preparation strategy & direction, speedy revision
- ▶ Chapter-wise important Problem-Solving
- ▶ Theory, Formulas & Diagrams to crack JEE
- ▶ Detailed high quality video lectures by experienced faculties
- ▶ JEE full preparation for Class XI & XII



**misostudy**  
connect smart learning

**JEE·NEET·AIIMS·CBSE·FOUNDATION**  
[www.misostudy.com](http://www.misostudy.com)

☎ 8929803804 (MON-FRI: 9am-6pm) [support@misostudy.com](mailto:support@misostudy.com)

MISO STUDY INDIA PVT. LTD.  
2ND FLOOR 65-A, OMPRO TOWER, KALU SARAI, NEW DELHI, DELHI 110016

# Class 12 | Chemistry

## 02 Solid State

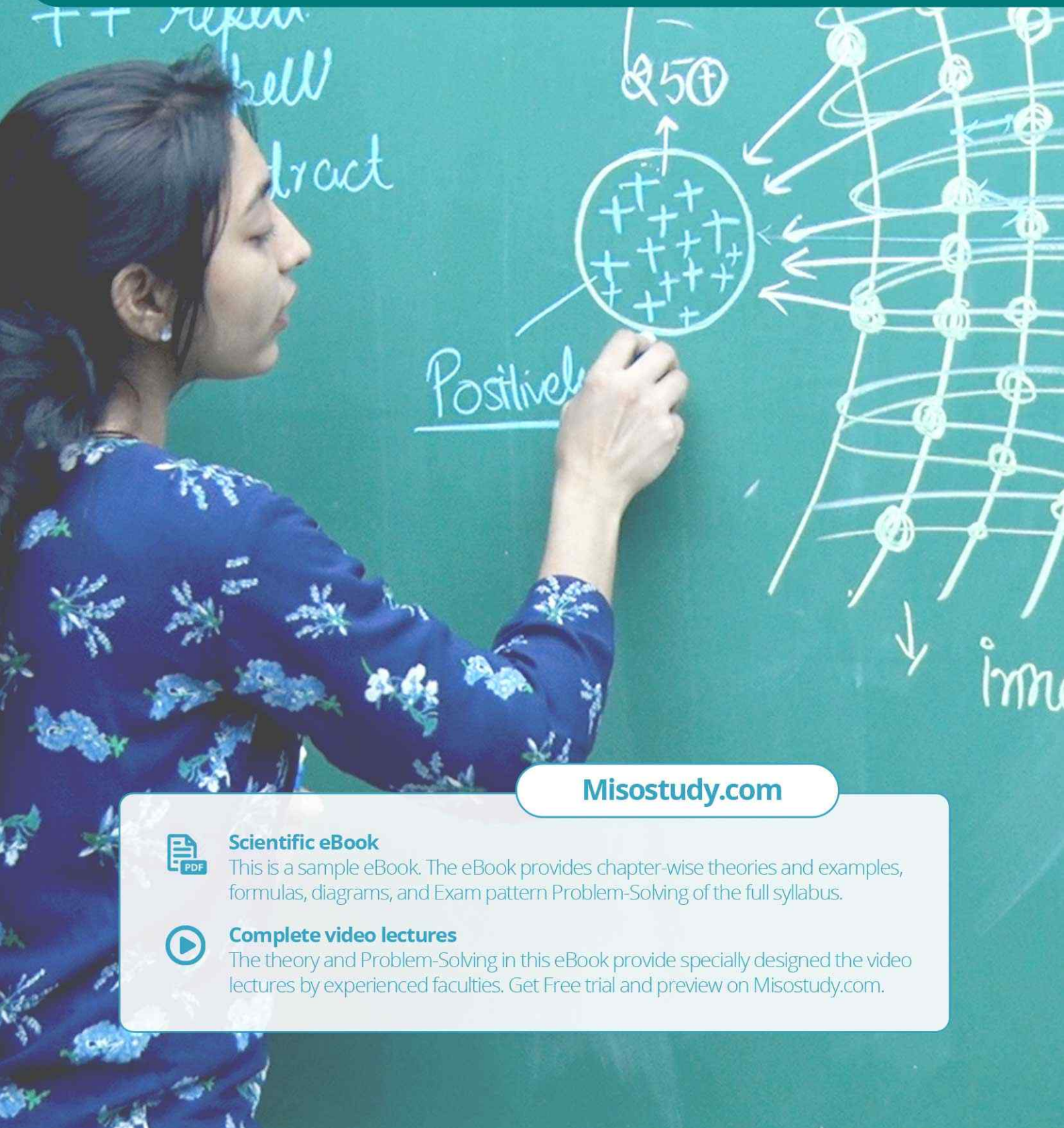

Misostudy.com



### Scientific eBook

This is a sample eBook. The eBook provides chapter-wise theories and examples, formulas, diagrams, and Exam pattern Problem-Solving of the full syllabus.



### Complete video lectures

The theory and Problem-Solving in this eBook provide specially designed the video lectures by experienced faculties. Get Free trial and preview on Misostudy.com.

## 01. The Solid State

The solids are characterized by incompressibility, rigidity and mechanical strength. The molecules, atoms or ions in solids are closely packed i.e they are held together by strong forces and can not move about at random. Thus solids have definite volume, shape, low vapour pressure and possess the unique property of being rigid. Such solids are known as true solids e.g. NaCl, KCl, Sugar, Ag, Cu etc. On the other hand the solid which loses shape on long standing, flows under its own weight and is easily distorted by even mild distortion forces are called pseudo solids e.g. glass, plastic etc.

Some solids such as NaCl, Sugar, Sulphur etc. have properties not only of rigidity and incompressibility but also of having typical geometrical forms. These solids are called as crystalline solids. In such solids there is definite arrangement of particles (atoms, ions or molecules) throughout the entire three dimensional network of a crystal. This is named as long-range order. This three dimensional arrangement is called **crystal lattice or space lattice**. Other solids such as glass, rubber, plastics etc. have rigidity and incompressibility to a certain extent but they do not have definite geometrical forms or do not have long range order are known as amorphous solids.

## 02. Differences Between Crystalline and Amorphous Solids

### (i). Characteristic Geometry

In the crystalline solids the particles (atoms, ions, or molecules) are definitely and orderly arranged thus these have characteristic geometry while amorphous solids do not have characteristic geometry.

### Melting Points

A crystalline solid has a sharp melting point i.e. it changes into liquid state at a definite temperature. On the contrary an amorphous solid does not have a sharp melting point.

### Cooling curve

Amorphous solids show a smooth cooling curve while crystalline solids show two breaks in the cooling curve. In the case of crystalline solids two break points 'a' and 'b' appear. These points indicate the beginning and the end of the process of crystallization. In this time interval the temperature remains constant. This is due to the fact that during the crystallization process energy is liberated which compensates for the loss of heat thus the temperature remains constant.

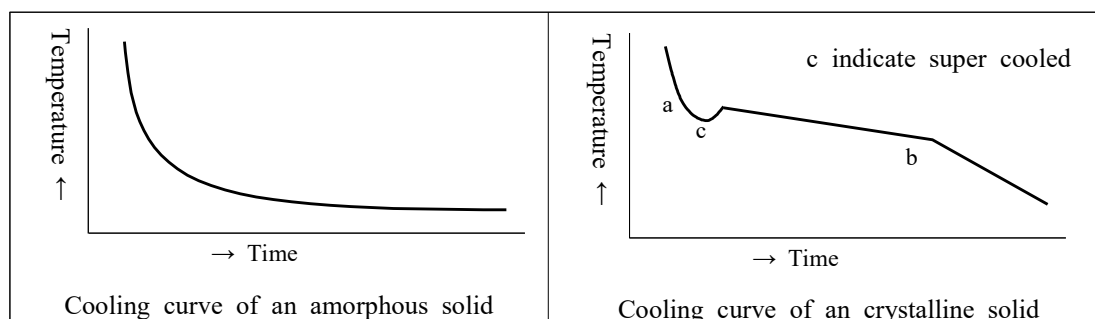

(i). **Isotropy and Anisotropy**

Amorphous solids differ from crystalline solids and resemble liquids in many respects. The properties of amorphous solids, such as electrical conductivity, thermal conductivity, mechanical strength, refractive index, coefficient of thermal expansion etc. are same in all directions. Such solids are known as isotropic. **Gases and liquids are also isotropic.**

On the other hand crystalline solids show these physical properties different in different directions. Therefore crystalline solids are called anisotropic.

### 03. Crystalline State

“A crystal is a solid composed of atoms (ions or molecules) arranged in an orderly repetitive array”

“**The smallest geometrical position of the crystal which can be used as repetitive unit to build up the whole crystal is called a unit cell.**” The unit cell should have same symmetry elements as the crystal and there should be no gaps between unit cells.

The angle between the two perpendiculars to the two intersecting faces is termed as the interfacial angle which may be same as the angle between the unit cell edges. Goniometer is used to measure the interfacial angle. It is important to note that interfacial angle of a substance remains the same although its shape may be different due to conditions of formation.

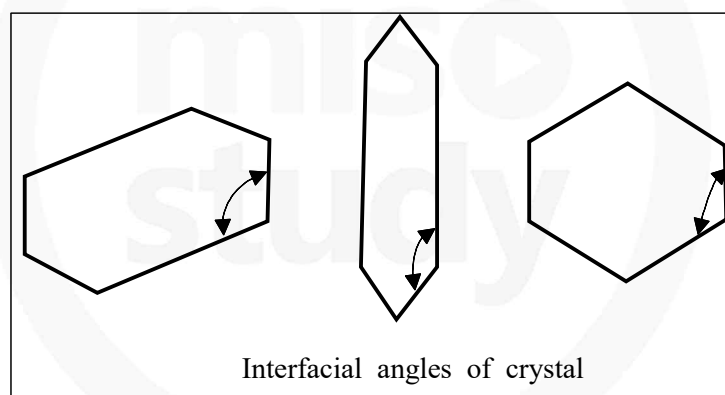

### 04. Types of the Crystals

Crystals are divided into four important types on the basis of chemical bonding of the constituent atoms.

(i) **Ionic Crystals**

These are formed by a combination of highly electro-positive ions (cations) and highly electronegative ions (anions). Thus strong electrostatic force of attraction acts within the ionic crystals. Therefore, a large amount of energy is required to separate ions from one another.

e.g. NaCl, KF, CsCl etc.



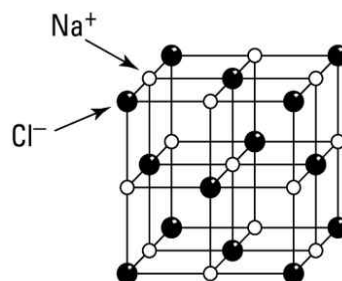

(ii) **Covalent Crystals**

These are formed by sharing of valence electrons between two atoms resulting in the formation of a covalent bond. The covalent bonds extend in two or three dimensions forming a giant interlocking structure called network. Diamond and graphite are the good examples of this type.

(iii) **Molecular Crystals**

In these crystals, molecules occupy the lattice points of the unit cells, except in solidified noble gases in which the units are atoms, where the binding is due to vander Waal's forces and dipole-dipole forces. Since vander Waal's forces are non-directional hence structure of the crystal is determined by geometric consideration only. Solid  $H_2$ ,  $N_2$ ,  $O_2$ ,  $CO_2$ ,  $I_2$ , sugar etc. are well known examples of such crystal in which vander Waal's forces are acting.

(iv) **Metallic Crystals**

These are formed by a combination of atoms of electropositive elements. These atoms are bound by metallic bonds. It may be defined as:  
The force that binds a metal ion to a number of electrons within its sphere of influences is known as metallic bond.

## 05. Isomorphism

The occurrence of a given substance in more than one solid crystalline forms have different physical properties is known as polymorphism. This property when occurs in elements is known as allotropy.

Sometimes we come across examples of chemically different solids which crystalline in the crystalline shape. Such substances are said to be Isomorphous (same shape). Their chemical constitutions are very similar and in some cases crystals of one substance may continue to grow when placed in a saturated solution of the other e.g. potash alum and chrome alum crystals have the same shape and can be grown in each other's solutions.

## 06. SPACE LATTICE/CRYSTALLINE LATTICE/3-D LATTICE

Space lattice is a regular arrangement of lattice points showing how the particles are arranged at different sites in 3D-view.

“The three dimensional distribution of component particles in a crystal can be found by X-ray diffraction of different faces of the crystal. On the basis of the classification of symmetry, the crystals have been divided into seven systems. These can be grouped into 32 classes which in turn can be regrouped into 7 crystal systems. These seven systems with the characteristics of their axes (angles and intercepts) along with some examples of each are given in the following table.

**The Seven Crystal System**

Name of system		Axes	Angles	Bravais Lattices
1.	Cubic [Isometric]	$a = b = c$	$\alpha = \beta = \gamma = 90^\circ$	Primitive, Face-centred, Body centred = 3
2.	Tetragonal	$a = b \neq c$	$\alpha = \beta = \gamma = 90^\circ$	Primitive, Body centred = 2
3.	Rhombohedral or Trigonal	$a = b = c$	$\alpha = \beta = \gamma \neq 90^\circ$	Primitive = 1
4.	Orthorhombic or Rhombic	$a \neq b \neq c$	$\alpha = \beta = \gamma = 90^\circ$	Primitive, Face-centred, Body centred End centred = 4
5.	Monoclinic	$a \neq b \neq c$	$\alpha = \gamma = 90^\circ$ ; $\beta \neq 90^\circ$	Primitive, End – centred = 2
6.	Triclinic	$a \neq b \neq c$	$\alpha \neq \beta \neq \gamma \neq 90^\circ$	Primitive = 1
7.	Hexagonal	$a = b \neq c$	$\alpha = \beta = 90^\circ$ $\gamma = 120^\circ$	Primitive = 1 Total = 14

## 07. Types of Unit Cells

There are four types of unit cells (among the cubic system).

(a) Simple or primitive. Particles are only at the corners of the unit cell.

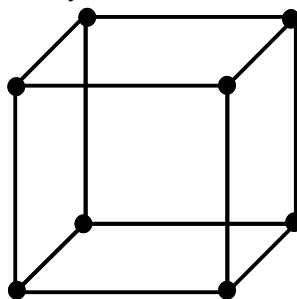

- (b) Face-centred cubic unit cell. A particle is present at the centre of each face of the unit cell.

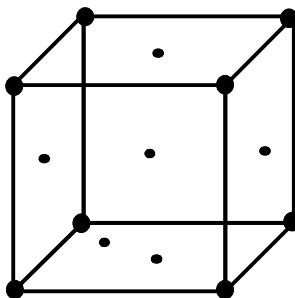

- (c) End-face-centred cubic unit cell. A particle is present at each corner plus particles are present on the end faces of the unit cell.

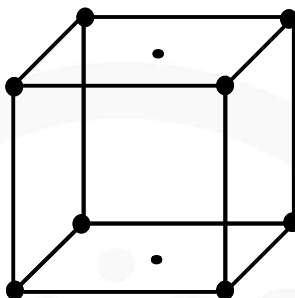

- (d) Body-centred cubic unit cell. In addition to the particles at the corners, there is one particle in the body-centre of the unit cell.

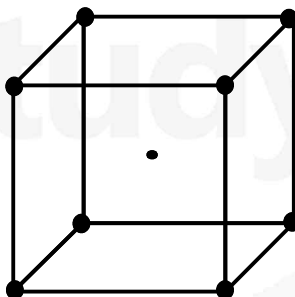

## 08. Coordination Number

If atoms are represented by spheres, the number of spheres which are touching a particular sphere is called *coordination number* of that sphere. In ionic crystals, the coordination number may be defined as the number of the oppositely charged ions surrounding a particular ion.

### 09. The number of particles per Unit Cell

- (i) An atom at the corner is shared by 8 unit cells. Therefore, its contribution is =  $1/8$ .
- (ii) An atom at the face is shared by 2 unit cells. Therefore, its contribution is =  $1/2$ .
- (iii) An atom present in the body is unshared. Therefore, its contribution is 1.
- (iv) An atom present on the edge is shared by four unit cells. Therefore, its contribution is =  $1/4$ . Thus, in
- (v) a primitive or simple cubic unit cell, the total number of particles is  $1/8 \times 8 = 1$ .
- (vi) a face-centred cubic unit cell; the total number of particles is  $1/8 \times 8 + 1/2 \times 6 = 4$ .
- (vii) a body-centred cubic unit cell, the total number of particles is  $1/8 \times 8 + 1 = 2$ .

The number of atoms per unit cell are in the same ratio as the stoichiometry of the compound or the ratio of the number of particles A and B present per unit cell gives the formula of the compound formed between A and B.

### 10. LENGTH OF FACE DIAGONAL AND CUBE DIAGONAL

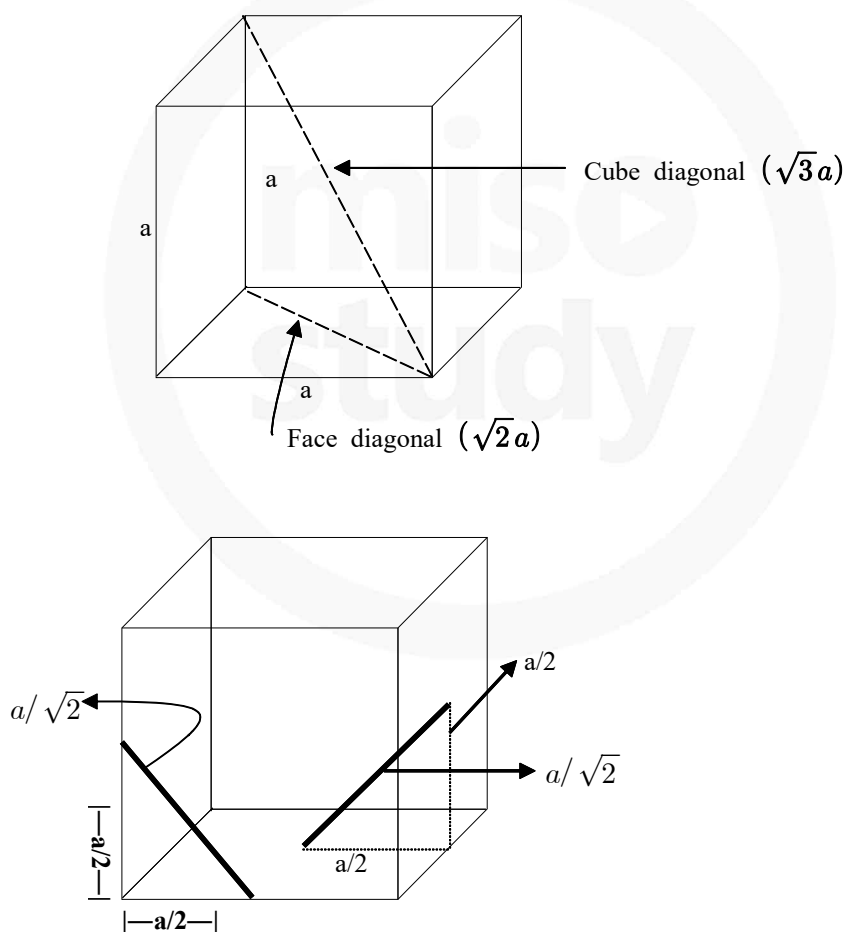

Consider the triangle ABC, with the help of pythagoras theorem  
 $AC = \sqrt{AB^2 + BC^2} = \sqrt{a^2 + a^2} = \sqrt{2}a$  (length of face diagonal.)

Consider the triangle DAC, with the help of pythagoras theorem

$$DC = \sqrt{DA^2 + AC^2} = \sqrt{a^2 + (\sqrt{2}a)^2} = \sqrt{3}a \quad (\text{length of cube diagonal})$$

### TYPES OF UNIT CELL (BRAVAIS LATTICE)

The distance between successive lattice planes of the same type is called the spacing of planes or inter planar distance between the planes. On the basis of this aspect, the lattices may be divided in following classes.

## 11. Simple/Primitive/Basic Unit cell

A unit cell having lattice point only at corners called as primitive or simple unit cell. i.e. in this case there is one atom at each of the eight corners of the unit cell considering an atom at one corner as the centre, it will be found that this atom is surrounded by six equidistant neighbours (atoms) and thus the co-ordination number will be six. If 'a' is the side of the unit cell, then the distance between the nearest neighbours shall be equal to 'a'.

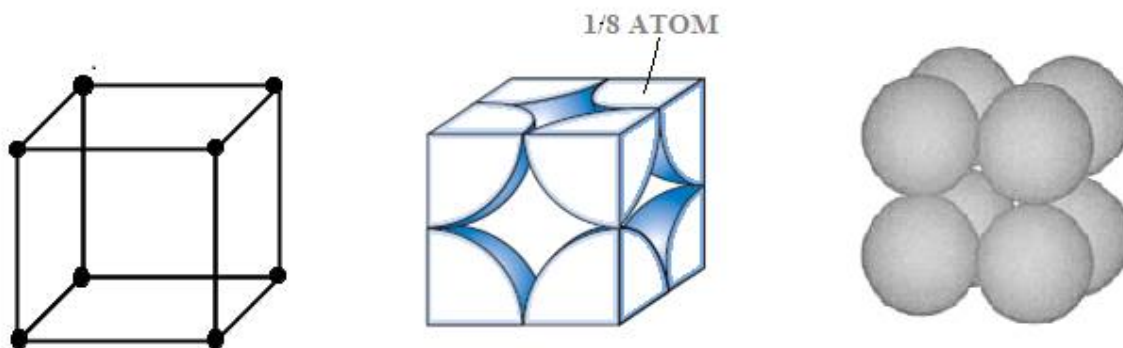

(a) Relationship between edge length 'a' and atomic radius 'r' :

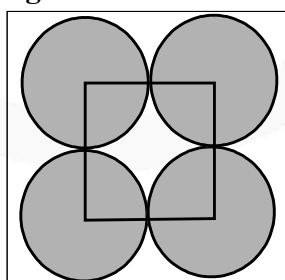

$$a=2r$$

$$\text{i.e. } r = \frac{a}{2} \quad (\text{One face of SCC})$$

(b) Number of atoms present in unit cell

In this case one atom or ion lies at the each corner. Hence simple cubic unit cell contains a total of  $\frac{1}{8} \times 8 = 1$  atom or ion/unit cell.

## (c) Packing efficiency(P. E.)

$$\text{P.E.} = \frac{\text{Volume occupied by atoms present in unit cell}}{\text{Volume of unit cell}}$$

$$= \frac{n \times \frac{4}{3} \pi r^3}{V} \quad [\because \text{Volume of atom} = \frac{4}{3} \pi r^3]$$

$$\text{For SCC : P.E.} = \frac{1 \times \frac{4}{3} \times \pi \times \left(\frac{a}{2}\right)^3}{a^3} \quad [\because r = \frac{a}{2} \text{ and } V = a^3, n = 1]$$

$$= \frac{\pi}{6} = 0.524 \text{ or } 52.4\%$$

## 12. Body centred cubic (b.c.c.) cell:

A unit cell having lattice point at the body centre in addition to the lattice point at every corner is called as body centered unit cell.

Here the central atom is surrounded by eight equidistant atoms and hence the co-ordination number is eight. The nearest distance between two atoms will be  $\frac{a\sqrt{3}}{2}$

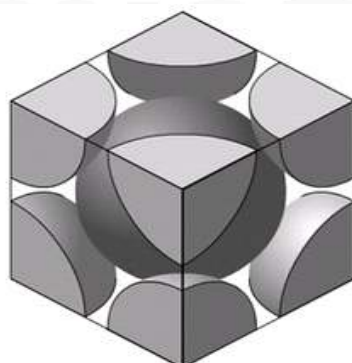

## (a) Relationship between edge length 'a' and atomic radius 'r' :

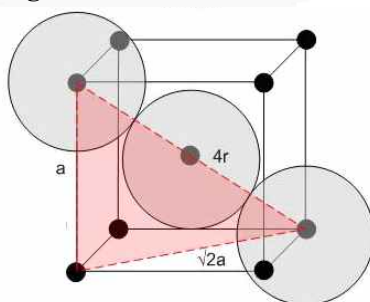

In BCC, along cube diagonal all atoms touches each other and the length of cube diagonal is  $\sqrt{3}a$

$$\text{So, } \sqrt{3}a = 4r \quad \text{i.e. } r = \frac{\sqrt{3}a}{4}$$

(b) **Number of atom present in unit cell:**

$$\left(\frac{1}{8} \times 8\right) + (1 \times 1) = 1 + 1 = 2 \text{ atoms/unit cell}$$

In this case one atom or ion lies at the each corner of the cube. Thus contribution of the 8 corners is  $\left(\frac{1}{8} \times 8\right) = 1$ , while that of the body centred is 1 in the unit cell. Hence total number of atoms per unit cell is  $1 + 1 = 2$  atoms (or ions)

(c) **Packing efficiency:**

$$\text{P.E.} = \frac{n \times \frac{4}{3} \pi r^3}{V} = \frac{2 \times \frac{4}{3} \times \pi \left(\frac{\sqrt{3}a}{4}\right)^3}{a^3} = \frac{\sqrt{3}\pi}{8} = 0.68 \quad \left[ \because n = 2, r = \frac{\sqrt{3}a}{4}, V = a^3 \right]$$

In B.C.C. 68% of total volume is occupied by atom or ions.

### 13. Face centred cubic (f.c.c.) cell:

A unit cell having lattice point at every face centre in addition to the lattice point at every corner called as face centred unit cell. i.e. in this case there are eight atoms at the eight corners of the unit cell and six atoms at the centre of six faces. Considering an atom at the face centre as origin, it will be found that this face is common to two cubes and there are twelve points surrounding it situated at a distance which is equal to half the face diagonal of the unit cell. Thus the co-ordination number will be twelve and the distance between the two nearest atoms will be  $\frac{a}{\sqrt{2}}$ .

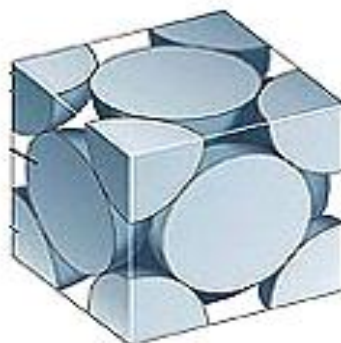

(a) **Relationship between edge length 'a' and atomic radius 'r' :**

In FCC, along the face diagonal all atoms touches each other and the length of face diagonal is  $\sqrt{2}a$ .

$$\text{So } 4r = \sqrt{2}a \quad \text{i.e. } r = \frac{\sqrt{2}a}{4} = \frac{a}{2\sqrt{2}}, \quad r = \frac{a}{2\sqrt{2}}$$

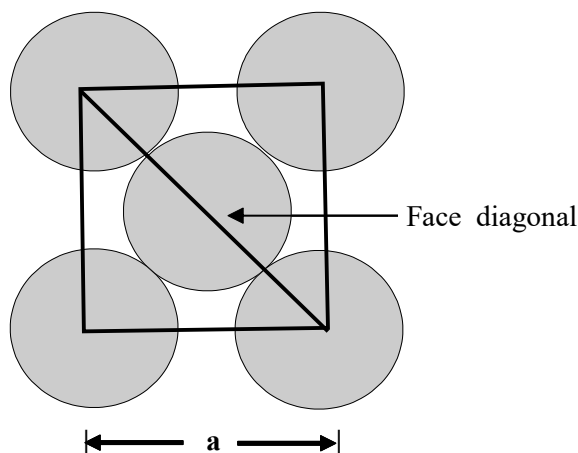

(b) **Number of atoms per unit cell :**

$$\left(\frac{1}{8} \times 8\right) + \left(6 \times \frac{1}{2}\right) = 1 + 3 = 4 \text{ atoms/unit cell}$$

In this case one atom or ion lies at the each corner of the cube and one atom or ion lies at the centre of each face of the cube. It may noted that only  $\frac{1}{2}$  of each face sphere lie with in the unit cell and there are six such faces. The total contribution of 8 corners is  $\left(\frac{1}{8} \times 8\right) = 1$ , while that of 6 face centred atoms is  $\left(\frac{1}{2} \times 6\right) = 3$  in the unit cell.

Hence total number of atoms per unit cell is  $1+3 = 4$  atoms (or ions).

(c) **Packing efficiency :**

$$\begin{aligned} \text{P.E.} &= \frac{n \times \frac{4}{3} \pi r^3}{V} \quad \left[ \because \text{for FCC } n = 4, r = \frac{a}{2\sqrt{2}}, V = a^3 \right] \\ &= \frac{4 \times \frac{4}{3} \pi \times \left(\frac{a}{2\sqrt{2}}\right)^3}{a^3} = \frac{\pi}{3\sqrt{2}} = 0.74 \text{ or } 74\% \end{aligned}$$

i.e. In FCC, 74% of total volume is occupied by atoms.

#### 14. End Centered Unit Cell:

A unit cell having lattice point at the centres of only. one set of opposite faces in addition to the lattice point at every corner called as end centered unit cell.

**NOTE** This type of Bravais lattice is obtained only in orthorhombic and monoclinic type unit call.



### 15. CRYSTAL DENSITY OF THE CRYSTAL

If the length of edge of the unit cell is known we can calculate the density of the crystal as follow: Let length of edge of the unit cell be  $\ell$ .

$$\therefore \text{Volume of the unit cell} = \ell^3 = V \text{ cm}^3$$

$$\text{Density of the unit cell} = \frac{\text{Mass of unit cell}}{\text{Volume of unit cell}}$$

Mass of the unit cell = Number of atoms present in a unit cell  $\times$  Mass of one atom =  $n \times m$  g

$$\text{But mass of one atom (m)} = \frac{\text{Atomic mass}}{\text{Avogadro Number}} = \frac{M}{N_A}$$

$$\text{Mass of the unit cell} = n \times \frac{M}{N_A} \text{ g}$$

$$\text{Density of the unit cell} = \frac{n \times \frac{M}{N_A}}{V} \text{ gm cm}^{-3}$$

$$\text{Density of the unit cell} = \frac{n \times M}{V \times N_A} \text{ g cm}^{-3} = \text{Crystal density (}\rho\text{)}$$

**Example** An element (atomic mass = 60) having face centred cubic crystal has a density of  $6.23 \text{ g cm}^{-3}$ . What is the edge length of the unit cell (Avogadro constant,  $N_A = 6.02 \times 10^{23} \text{ mol}^{-1}$ ).

**Solution**

$$\text{Density} = \frac{Z \times M}{a^3 \times N_A} \quad Z = 4 \text{ (for fcc)}$$

$$6.23 = \frac{4 \times 60}{a^3 \times 6.022 \times 10^{23}} \quad a^3 = \frac{4 \times 60}{6.23 \times 6.022 \times 10^{23}}$$

$$= 64 \times 10^{-24}$$

$$a = 4 \times 10^{-8} \text{ cm}$$

$$= 4 \times 10^{-10} \text{ m} = 400 \text{ pm.}$$

### 16. Close packing

It is type of packing with maximum packing fraction & space utilization. The constituent particles of a solid are like hard spheres. These spheres can pack in space in various manner to form a packing. To clearly understand the packing of these spheres, the packing can be categorised as :

- (i) Close packing in one dimension.
- (ii) Close packing in two dimension.
- (iii) Close packing in three dimension.

### 17. Close packing in one dimension :

In one dimension, only one arrangement of spheres is possible as shown in fig.

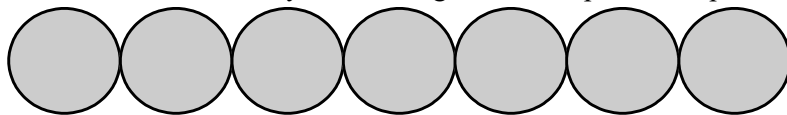

Close packing of spheres in one dimension

### Two dimensional packing of spheres :

Two possible types of two dimensional packing are.

- (i) Square close packing in two dimension.
- (ii) Hexagonal close packing in two dimension.

### 18. Two dimensional square packing of spheres :

When two rows are placed in such a manner, that spheres of one row are placed immediately below of the other, the resulting packing is called two dimensional square close packing.

- (i) Since all the rows are identical the packing is called AAA ..... type packing.
- (ii) Each sphere is touched by four other hence coordination number is four.
- (iii) Of centres of spheres are connected, square cells are formed, hence also called two dimensional square packing.
- (iv) This type of packing is not very effective in terms of utilization of space.

(v) Packing efficiency in 2-D =  $\frac{1 \times \pi r^2}{a^2} = \frac{1 \times \pi (a/2)^2}{a^2} = \frac{\pi}{4} = 0.74$  .

(vi) Packing efficiency in 3-D =  $\frac{1 \times \frac{4}{3} \pi \left(\frac{a}{2}\right)^3}{a^3} = 0.52$  [In 3-D its unit cell is simple cubic]

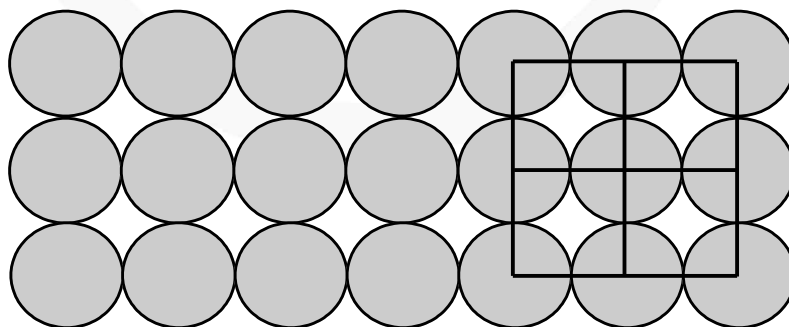

### 19. Two dimensional hexagonal packing :

If various one dimensional close pack rows are placed in such a way that spheres of top row fits in depression of bottom row spheres, the resulting packing is called two dimensional close packing structure.

- Every third row sphere comes exactly at top of first row sphere, hence the packing is called ABABAB packing.
- If centres are joined, hexagonal unit cells are formed. Hence this is called two dimensional hexagonal close packing.
- This packing is most efficient in utilizing space in two dimensional arrangement.
- Each sphere is touched by six other, hence coordination number is six.

$$(v) \text{ Packing efficiency in 2-D} = \frac{3 \times \pi \left(\frac{a}{2}\right)^2}{\frac{a^3 \sqrt{3}}{4} \times 6} = \frac{\pi}{2\sqrt{3}} = 0.91$$

$$(vi) \text{ Packing efficiency in 3-D} = \frac{3 \times \frac{4}{3} \pi \left(\frac{a}{2}\right)^3}{\frac{a^2 \sqrt{3}}{4} \times 6 \times a} = \frac{\pi}{3\sqrt{3}} = 0.60$$

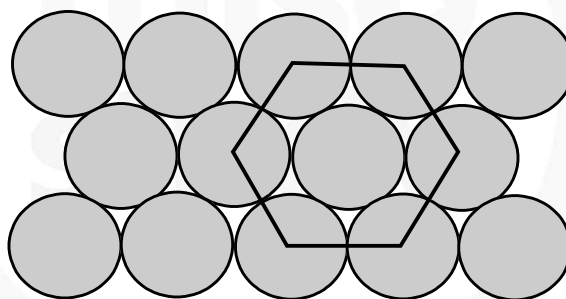

### 20. Close packing in three dimensions :

When two dimensional packing structure are arranged one above the other, depending upon type of two dimensional arrangement in a layer, and the relative positions of spheres in above or below layer, various types of three dimensional packing results. To define 3-D lattice six lattice parameters are required – 3 edge lengths & 3 angles.

- Simple cubic packing (A A A A)
- Hexagonal close packing (AB AB AB .....
- Cubic close packing or face centered cubic (...ABC ABC...)

## 21. Simple cubic packing in three dimension :

The two dimensional square close packed layer are placed, in such a manner that spheres in each layer comes immediately on top of below layer, simple cubic packing results. Important points.

- (i) Atoms all aligned vertically and horizontally in all directions.
- (ii) The unit cell for this packing is simple cubic unit cell.
- (iii) In this packing, only 52% of available space is occupied by atoms.

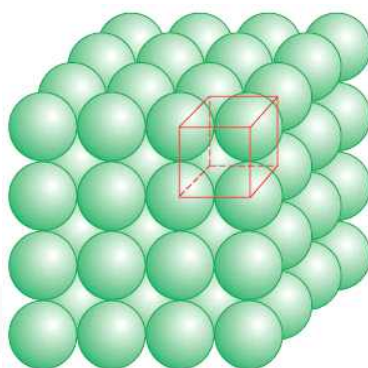

## 22. Three Dimensionally close packing :

In hexagonal close packing, there are two types of the voids (open space or space left) which are divided into two sets 'b' and 'c' for convenience. The spaces marked 'c' are curved triangular spaces with tips pointing upwards whereas spaces marked 'b' are curved triangular spaces with tips pointing downwards. Now we extend the arrangement of spheres in three dimensions by placing second close packed layer (hexagonal close packing) (B) on the first layer (A). The spheres of second layer may placed either on space denoted by 'b' or 'c'. It may be noted that it is not possible to place sphered on both types of voids (i.e. b and c). Thus half of the voids remain unoccupied by the second layer. The second layer also have voids of the types 'b' and in order to build up the third layer, there are following two ways :

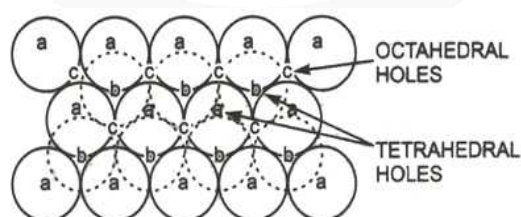

### 23. Hexagonal close packing (HCP) AB-AB-AB ..... Type :

- (i) In one way, the spheres of the third layer lie on spaces of second layer (B) in such a way that they lie directly above those in the first layer (A). In other words we can say that the layer becomes identical to the first layer. If this arrangement is continued indefinitely in the same order this represented as A B A B A B .....  
This type of arrangement represent hexagonal close packing (hcp) symmetry (or structure), which means that the whole structure has only one 6-fold axis of symmetry i.e. the crystal has same appearance on rotation through an angle of  $60^\circ$ .
- (ii) Every third layer sphere lies on top of first layer sphere. (ABABAB ..... packing)
- (iii) Maximum possible space is occupied by spheres.
- (iv) Each sphere is touched by 12 other spheres in 3D  
(6 in one layer, 3 in top layer and 3 in bottom.)
- (v) The unit cell for hexagonal close packing is hexagonal unit cell.
- (vi) For every atom forming hcp there are effectively two tetra voids and one octa void.  
That why this generate ABAB ..... AB pattern. One type of void always remain on unoccupied.

Unit cell :  $a = 2r = b$ ;  $\gamma = 120^\circ$

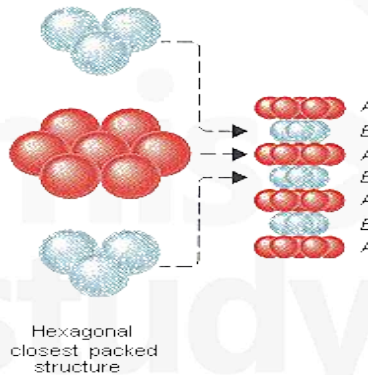

#### (vii) Packing efficiency of HCP units

Relation between  $a$ ,  $b$ ,  $c$  and  $R$  :

$$a = b = 2R$$

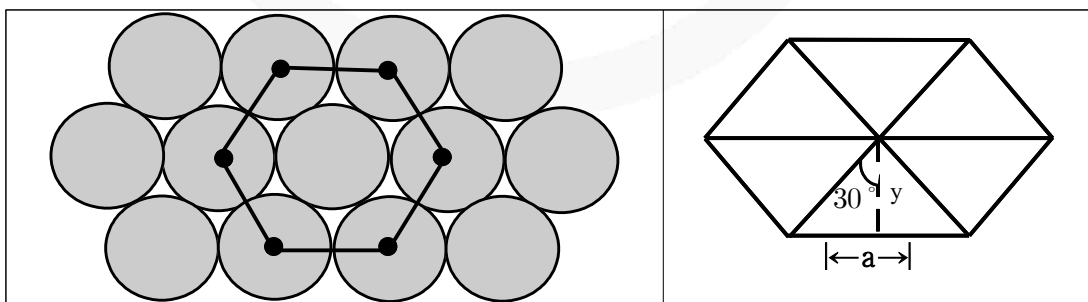

$$\tan 30 = \frac{a}{2 \times y}$$

so

$$y = \frac{a \times \sqrt{3}}{2 \times 1} = \frac{\sqrt{3}}{2} a.$$

$$\text{Area} = 6 \left[ \frac{1}{2} a \times \frac{\sqrt{3}}{2} a \right] = \frac{6\sqrt{3}a^2}{4}$$

Calculation of  $c$  :

$$\cos 30^\circ = \frac{a}{2 \times x} \quad x = \frac{2a}{2 \times \sqrt{3}} = \frac{a}{\sqrt{3}}$$

Applying pythagoras theorem :  $x^2 + h^2 = a^2$

$$\text{So } h^2 = a^2 - x^2 = a^2 - \frac{a^2}{3} = \frac{2}{3} a^2$$

$$h = \frac{2}{\sqrt{3}} a \quad \text{so } c = 2h = 2\sqrt{\frac{2}{3}} a$$

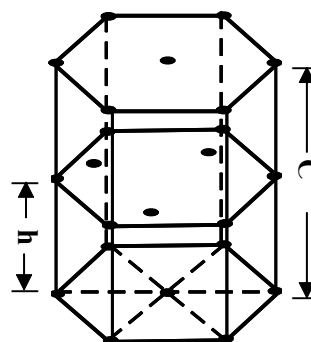

## 24. ABC – ABC arrangement (Cubic close packing (FCC))

In second way, the spheres of the third layer (C) lie on the second layer (B) in such a way that they lie over the unoccupied spaces 'C' of the first layer(A). If this arrangement is continuous in the same order this is represented as ABC ABC ABC..... This type of arrangement represent cubic close packed (ccp) structure. This structure has 3-fold axes of symmetry which pass through the diagonal of the cube. since in this system, there is a sphere at the centre of each face of the unit cell and hence this structure is also known as face-centred cubic (fcc) structure. It may be noted that in ccp (or fcc) structures each sphere is surrounded by 12 spheres hence the coordination number of each sphere is 12. The spheres occupy 74% of the total volume and 26% of is the empty space in both (hcp and ccp) structure.

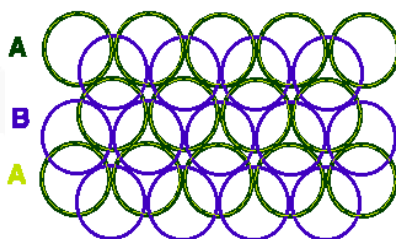

- III<sup>rd</sup> layer will be different from I<sup>st</sup> layer as well as II<sup>nd</sup> layer.
- It is also known as cubical close packing (CCP), unit cell chosen is face centered unit cell (FCC).

Relation between 'a' and 'R' :

$$a \neq 2R \quad \sqrt{2}a = 4R \text{ (Sphere are touching along the face diagonal)}$$

$$\text{Effective no. of atoms per unit cell (Z)} = Z = \frac{1}{8} \times 8 + \frac{1}{2} \times 6 = 4$$

**Packing fraction**

$$\text{P.F.} = \frac{4 \times \frac{4}{3} \pi R^3}{4 \times 4 \times 4 R^3} \times \sqrt{2} \times 2 = \frac{\pi}{3\sqrt{2}} = 0.74 \text{ (74\%)}$$

**Coordination number , (CN) = 12**

$$\text{Density (d)} = \frac{Z \times M}{N_A \cdot a^3}$$

**INTERSTICES OR VOIDS OR HOLES IN CRYSTALS**

It has been shown that the particles are closely packed in the crystals even than there is some empty space left in between the spheres. This is known as interstices (or interstitial site or hole empty space or voids). In three dimensional close packing (CCP & HCP) the interstices are of two types : (i) tetrahedral interstices and (ii) octahedral interstices.

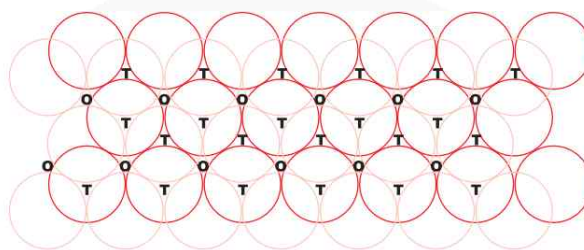
**25. Tetrahedral Interstices :**

We have seen that in hexagonal close packing (hcp) and cubic close packing (ccp) each sphere of second layer touches with three spheres of first layer. Thus they, leave a small space in between which is known as **tetrahedral site or interstices**. or The vacant space between 4 touching spheres is called as tetrahedral void. Since a sphere touches three spheres in the below layer and three spheres in the above layer hence there are two tetrahedral sites associated with one sphere. It may be noted that a tetrahedral site does not mean that the site is tetrahedral in geometry but it means that this site is surrounded by four spheres and the centres of these four spheres lie at the apices of a regular tetrahedron.

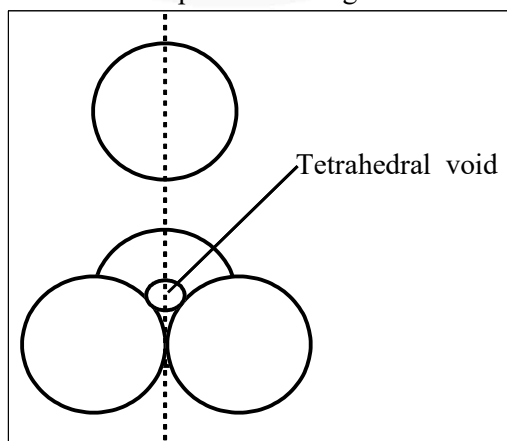

In FCC, one corner and its three face centred atom of faces meeting at that corner form a tetrahedral void.

In FCC, two tetrahedral voids are obtained along one cube diagonal. So in FCC 8 tetrahedral voids are present.

In FCC total number of atoms = 4

In FCC total number of tetrahedral voids = 8

So, we can say that, in 3D close packing 2 tetrahedral voids are attached with one atom.

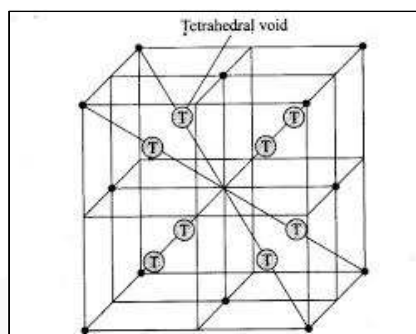

## 26. Octahedral – Interstices :

Hexagonal close packing (hcp) and cubic close packing (ccp) also form another type of interstices (or site) which is called octahedral site (or interstices). or The vacant space between 6 touching spheres is called as octahedral void.

In the figure two layers of close packed spheres are shown. The spheres of first layer are shown by full circles while that of second layer by dotted circles. Two triangles are drawn by joining the centres of three touching spheres of both the layers.

In FCC, 6 face centres form a octahedral void at body centre.

The apices of these triangles point are in opposite directions. On super imposing these triangles on one another a octahedral site is created. It may be noted that an octahedral site does not mean that the hole is octahedral in shape but it means that this site is surrounded by six nearest neighbour lattice points arranged octahedrally.

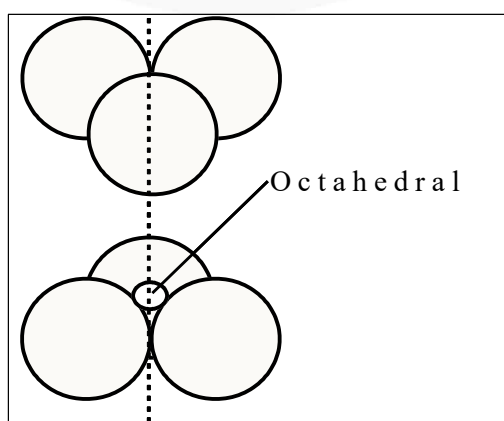



### 27. Positions of Tetrahedral Voids in an fcc Unit Cell :

The centre of tetrahedral void is located on the centre of body diagonal of each small cube of volume  $\left(\frac{a^3}{8}\right)$ .

$$\text{Total number of atoms per unit cell} = \frac{1}{2} \times 6 + 8 \times \frac{1}{8} = 4$$

Total number of tetra void = 8

Effective number of tetra void per atom forming close pack = 2.

If a fcc unit cell is divided into eight equal mini-cubes (edge =  $a/2$ ) then centre of tetra voids lies at the centres of each of these mini-cubes. In FCC center of tetra void is at perpendicular distance of  $a/4$  from nearest face.

### 28. Positions of Octahedral Voids in an fcc Unit Cell :

Position of octa void is at mid-point of each edge (total 12 edges in a cube) and at the centre of cube. Each octa void located at mid point of edge contributes  $1/4$  to the unit cell. The octa void situated at the centre contributes 1.

In FCC, total number of octahedral voids are

$$(1 \times 1) + \left(12 \times \frac{1}{4}\right) = 1 + 3 = 4$$

(Cube centre) (edge)

In FCC, number of atoms = 4

In FCC, number of octahedral voids = 4

So, we can say that, in any type of close packing one octahedral void is attached with one atom.

### 29. Limiting Radius Ratios

An ionic crystal contains a large number of cations and anions. Generally cations are smaller in size than anions. The cations are surrounded by anions and they touch each other. These ions are arranged in space in such a way to produce maximum stability. The stability of the ionic crystal may be described in terms of radius ratio i.e. the ratio of the radius of cation ( $r$ ) to that of anion ( $R$ ) is  $(r/R)$ . The range of  $(r/R)$  may be expressed as limiting radius ratio. This value is important to determine the arrangement of the ion in different types of crystals.

Limiting radius ratio for various types of sites

Limiting radius ratio = $r/R$	Coordination Number of cation	Structural Arrangement (Geometry of voids)	Example
0.155 – 0.225	3	Plane Trigonal	Boron Oxide
0.225 – 0.414	4	Tetrahedral	ZnS, SiO <sub>2</sub>
0.414 – 0.732	4	Square planar	– .
0.414 – 0.732	6	Octahedral	NaCl, MgO <sub>2</sub>
0.732 – 1.000	8	Cubic	CsCl

**Example** A solid  $A^+ B^-$  has NaCl type close packed structure. If the anion has a radius of 250 pm, what should be the ideal radius for the cation ? Can a cation  $C^+$  having a radius of 180 pm be slipped into the tetrahedral site of the crystal  $A^+ B^-$  ? Give reason for your answer.

**Solution** NaCl = FCC Closed packed structure

$$\frac{r_+(C^+)}{r_-(B^-)} = \frac{180\text{pm}}{250\text{pm}} = 0.72$$

It does not lie in the range 0.225–0.414. Hence,  $C^+$  cannot be slipped into the tetrahedral site.

### 30. STRUCTURE of NaCl :

The bigger  $Cl^-$  forms cubic close packing and small  $Na^+$  occupy positions of all octahedral voids. The radius ratio  $\frac{r^+}{r^-}$  lie in the range 0.414 – 0.73.

- (i) Each  $Na^+$  is surrounded by six  $Cl^-$  is surrounded by six  $Na^+$  ion. [6:6 coordination]
- (ii) Total no. of  $Na^+$  and  $Cl^-$  in each limit cell is 4.
- (iii) Number of formula units of NaCl per unit cell is equal to 4.

(iv) The density of NaCl crystal is given by  $d = \left( \frac{4 \times M_{NaCl}}{N_A \times a^3} \right)$

$N_A$  = Avogadro's number ;  $a$  = Edge length

The edge length of NaCl unit cell is given by  $(2r^+ + 2r^-) \Rightarrow \frac{a}{2} = r^+ + r^-$  (FCC & Octa void)

### 31. Zinc Blende (Sphalerite) Structure :

Larger anions form ccp arrangement and smaller cations filling half of alternate tetrahedral voids.

- (i) C.N. of  $Zn^{2+} = 4$  ; C.N. of  $S^{2-} = 4$  [4 : 4 coordination]
- (ii) Formula units of  $ZnS$  per unit cell = 4.

(iii)  $d_{ZnS} = \frac{4 \times M_{ZnS}}{N_A \times a^3}$

(iv)  $r_{Zn^{2+}} + r_{S^{2-}} = \frac{a\sqrt{3}}{4}$

### 32. Cesium Halide Structure :

(CsCl)  $\text{Cl}^-$  at the corners of cube and  $\text{Cs}^+$  in the center.

(i) C.N. of  $\text{Cs}^+$  = 8 ; C.N. of  $\text{Cl}^-$  = 8 [8 : 8 coordination]

(ii) Formula units of CsCl per cube = 1

$$\text{(iii) } d_{\text{CsCl}} = \frac{M_{\text{CsCl}}}{N_A \times a^3}$$

$$\text{(iv) } r_{\text{Cs}^+} = r_{\text{Cs}^-} = \frac{a\sqrt{3}}{2} \Rightarrow r^+ + r^- = \frac{a\sqrt{3}}{4} \text{ (FCC \& tetra void)}$$

### 33. Fluorite Structure :

( $\text{CaF}_2$ )  $\text{Ca}^{2+}$  forming ccp arrangement and  $\text{F}^-$  filling all tetrahedral voids.

(i) C.N. of  $\text{F}^-$  = 4 ; C.N. of  $\text{Ca}^{2+}$  = 8 [8 : 4 coordination]

(ii) Formula units of  $\text{CaF}_2$  per unit cell = 4

$$\text{(iii) } d_{\text{CaF}_2} = \frac{4 \times M_{\text{CaF}_2}}{N_A \times a^3}$$

$$\text{(iv) } r_{\text{Ca}^{2+}} + r_{\text{F}^-} = \frac{a\sqrt{3}}{4}$$

### 34. Imperfections In Solid

Any deviation from the perfectly ordered arrangement constitutes a defect or imperfection. These defects sometimes called thermodynamic defect because the number of these defects depends on the temperature. Crystals may also possess additional defect due to the presence of impurities. Imperfection not only modify the properties of solids but also give rise to new properties.

### 35. Stoichiometric Defects

Those compounds in which the number of positive and negative ions are exactly in the ratio indicated by their chemical formula are called stoichiometric compounds. eg NaCl (1:1). These solids show following types of defects :

### 36. Schottky Defect :

This type of defect is created when same number of positive ion and negative ion are missing from their respective positions leaving behind a pair of holes. Schottky defect is more common in ionic compounds with high co-ordination number and where the size of positive and negative ions are almost equal. The presence of large number of schottky defects in crystal results in significant decrease in its density. Eg. NaCl, KCl, CsCl, KBr etc.

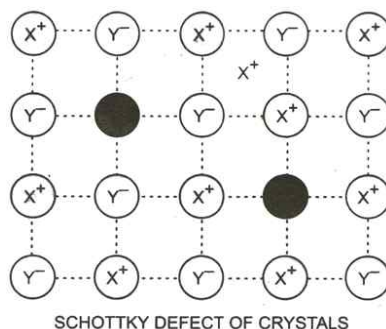

### 37. Interstitial Defect :

This type of defect is caused due to the presence of ions in the normally vacant interstitial sites in the crystal.

### 38. Frenkel Defect :

This type of defect is created when an ion leaves its correct lattice site and occupies an interstitial site. Frenkel defects are common in ionic compounds which have low co-ordination number and in which there is large difference in size between positive and negative ions. Eg. ZnS, AgCl, AgBr, Ag etc.

### 39. Non Stoichiometric Defect Frenkel Defect :

There are many compound in which the ratio of positive and negative ions present in the compound differs from that required by ideal formula of the compound. Such compounds are called Non stoichiometric compounds. eg.  $\text{VO}_x$  (Where  $x$  can vary between 0.6 to 1.3.) In these compounds balance of positive and negative charges is maintained by having extra electrons or extra positive charge. So, these defects are of following types:

#### 40. Metal Excess Defects Due to Anion Vacancies

A compound may have excess metal ion if a negative ion is absent from its lattice site, leaving a hole which is occupied by electron to maintain electrical neutrality. The holes occupied by electrons are called F-centres and are responsible for the colour of the compound.

Eg.

- The excess sodium in NaCl makes the crystal appears yellow.
- Excess potassium in KCl makes it violet.
- Excess lithium in LiCl makes it Pink.
- Greater the number of F-centres greater is the intensity of colour. This type of defects are found in crystal which are likely to possess schottky defects.

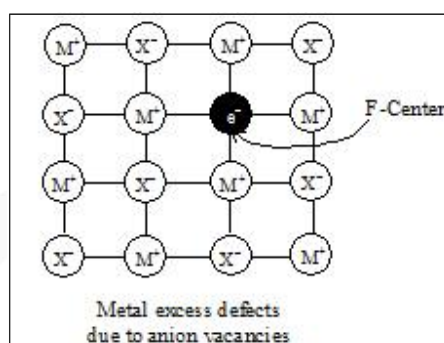

#### 41. Metal Excess Defects Due to Interstitial Cations

It may occur if an extra positive ion is present in an interstitial site, Electrically neutrality is maintained by the presence of an electron in the interstitial site. This type of defects are exhibited by the crystals which are likely to exhibit "Frenkel defects". Eg. Yellow colour of ZnS.

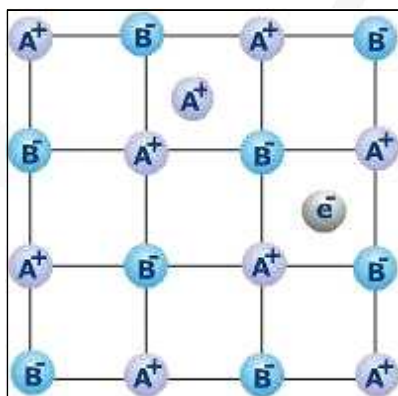

## 42. Metal Deficiency Due to Cation Vacancies

The non-stoichiometric compound may have metal deficiency due to the absence of a metal ion from its lattice site. The charge is balanced by an adjacent ion having higher positive charge. This type of defects are generally shown by compounds of transition metals.

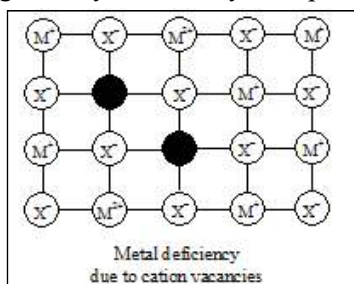

### Example

Analysis shows that nickel oxide has the formula  $\text{Ni}_{0.98}\text{O}$ . What fractions of the nickel exist as  $\text{Ni}^{2+}$  and  $\text{Ni}^{3+}$ ?

### Solution

Let  $\text{Ni}^{2+}$  be  $x$  so that  $\text{Ni}^{3+}$  will be  $0.98 - x$ . Total charge on the compound must be zero so that

$$+ 2x + 3(0.98 - x) - 2 = 0$$

$$2x + 2.94 - 3x - 2 = 0$$

$$-x = -0.94$$

or

$$x = 0.94$$

$$\% \text{ of } \text{Ni}^{2+} = \frac{0.94}{0.98} \times 100 = 96\%$$

$$\% \text{ of } \text{Ni}^{3+} = 4\%$$

## JEE Main Pattern Exercise (1)

- Q1. Sodium metal crystallizes in a body centered cubic lattice with a unit cell edge of 4.29Å. The radius of sodium atom is approximately.
- 1.86 Å
  - 3.22 Å
  - 5.72 Å
  - 0.93 Å
- Q2. CsCl crystallizes in body centred cubic lattice. If 'a' its edge length, then which of the following expressions is correct?
- $r_{\text{Cs}^+} + r_{\text{Cl}^-} = 3a$
  - $r_{\text{Cs}^+} + r_{\text{Cl}^-} = \frac{3a}{2}$
  - $r_{\text{Cs}^+} + r_{\text{Cl}^-} = \frac{\sqrt{3}}{2}a$
  - $r_{\text{Cs}^+} + r_{\text{Cl}^-} = \sqrt{3}a$
- Q3. Experimentally it was found that a metal oxide has formula  $M_{0.98}\text{O}$ . Metal  $M$ , present as  $M^{2+}$  and  $M^{3+}$  in its oxide. Fraction of the metal which exists as  $M^{3+}$  would be
- 7.01%
  - 4.08%
  - 6.05%
  - 5.08%
- Q4. Which of the following exists as covalent crystals in the solid state?
- Iodine
  - Silicon
  - Sulphur
  - Phosphorus
- Q5. In FCC unit cell, what fraction of edge is not covered by atoms?
- 0.134
  - 0.24
  - 0.293
  - None of these

Q6. The packing efficiency of two-dimensional square unit cell shown below is

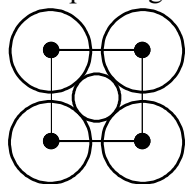

- (a) 39.27% (c) 74.05%  
(b) 68.02% (d) 78.54%

Q7. A substance  $A_xB_y$  crystallizes in a face centred cubic (fcc) lattice in which atoms  $A$  occupy each corner of the cube and atoms  $B$  occupy the centres of each face of the cube. Identify the correct composition of the substance  $A_xB_y$

- (a)  $AB_3$   
(b)  $A_4B_3$   
(c)  $A_3B$   
(d) composition cannot be specified

Q8. The coordination number of a metal crystallizing in a hexagonal close-packed structure is

- (a) 12  
(b) 4  
(c) 8  
(d) 6

Q9. Which of the following fcc structure contains cations in alternate tetrahedral voids?

- (a) NaCl  
(b) ZnS  
(c)  $Na_2O$   
(d)  $CaF_2$

Q10. A solid is formed and it has three types of atoms X, Y, Z. X forms a FCC lattice with Y atoms occupying all the tetrahedral voids and Z atoms occupying half the octahedral voids. The formula of the solid is:

- (a)  $XY_2Z$   
(b)  $XY_2Z_4$   
(c)  $X_2Y_4Z$   
(d)  $X_4YZ_2$





## Answer & Solution

---

### ANSWER

Q1	Q2	Q3	Q4	Q5
(a)	(c)	(b)	(b)	(c)
Q6	Q7	Q8	Q9	Q10
(d)	(a)	(a)	(b)	(c)

miso  
study

## JEE Advanced Pattern Exercise (1)

- Q1. The correct statement(s) regarding defects in solids is/are
- Frenkel defect is usually favoured by a very small difference in the sizes of cation and anion
  - Frenkel defect is a dislocation defect
  - Trapping of an electron in the lattice leads to the formation of F-centre
  - Schottky defects have no effect on the physical properties of solids

Q2. **Assertion and Reason**

- Statement I is correct Statement II is correct Statement II is the correct explanation of Statement I
- Statement I is correct Statement II is correct Statement II is not the correct explanation of Statement I
- Statement I is correct Statement II is incorrect
- Statement I is incorrect Statement II is correct

**Statement I**

In any ionic solid ( $MX$ ) with Schottky defects, the number of positive and negative ions are same.

**Statement II**

Equal numbers of cation and anion vacancies are present.

In hexagonal systems of crystals, a frequently encountered arrangement of atoms is described as a hexagonal prism. Here, the top of bottom of the cell are regular hexagons and three atoms are sandwiched in between them. A space-filling model of this structure, called hexagonal close-packed (hcp), is constituted of a sphere on a flat surface surrounded in the same plane by six identical spheres as closely as possible. Three spheres are then placed over the first layer so that they touch each other and represent the second layer. Each one of these three spheres touches three spheres of the bottom layer. Finally, the second layer is covered with a third layer that is identical to the bottom layer in relative position.

- Q3. The number of atoms in one of this hcp unit cell is

- 4
- 6
- 12
- 17

- Q4. The volume of this hcp unit cell is

- $24\sqrt{2}r^3$
- $16\sqrt{2}r^3$
- $12\sqrt{2}r^3$
- $\frac{64r^3}{3\sqrt{3}}$

Q5. The empty space in this hcp unit cell is

- (a) 74%
- (b) 47.6
- (c) 32%
- (d) 26%

Q6. Match the crystal system/unit cells mentioned in Column I with their characteristic features mentioned in Column II.

Column I		Column II	
A.	Simple cubic and face centred cubic	p.	have these cell parameters $a=b=c$ and $\alpha = \beta = \gamma = 90^\circ$
B.	Cubic and rhombohedral	q.	are two crystal systems
C.	Cubic and tetragonal	r.	have only two crystallographic angles of $90^\circ$
D.	Hexagonal and monoclinic	s.	belong to same crystal system

Q7. In FCC unit cell, what fraction of edge is not covered by atoms?

- (a) 0.134
- (b) 0.24
- (c) 0.293
- (d) None of these

Q8. Silver (atomic weight =  $108 \text{ g mol}^{-1}$ ) has a density of  $10.5 \text{ g cm}^{-3}$ . The number of silver atoms on a surface of area  $10^{-12} \text{ m}^2$  can be expressed in scientific notation as  $y \times 10^x$ . The value of  $x$  is

Q9. Which of the following Statement (s) is/are correct?

- (a) The coordination number of each type of ion in CsCl crystal is 8
- (b) A metal that crystallizes in bcc structure has a coordination number of 12
- (c) A unit cell of an ionic crystal shares some of its ions with other unit cells
- (d) The length of the unit cell in NaCl is 552 pm. ( $r_{\text{Na}^+} = 95 \text{ pm}$ ;  $r_{\text{Cl}^-} = 181 \text{ pm}$ )

Q10. The packing efficiency of two-dimensional square unit cell shown below is

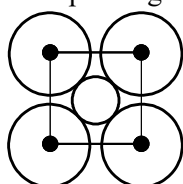

- (a) 39.27%
- (b) 68.02%
- (c) 74.05%
- (d) 78.54%



# Answer & Solution

## ANSWER

Q1	Q2	Q3	Q4	Q5
(b), (c)	(a)	(b)	(a)	(d)
Q6	Q7	Q8	Q9	Q10
(A) - p , s (B) - q (C) - q (D) - q , r	(c)	7	(a), (c), (d)	(d)

# JEE

# MATHEMATICS

- ▶ Specially designed eBook for complete JEE syllabus
- ▶ JEE preparation strategy & direction, speedy revision
- ▶ Chapter-wise important Problem-Solving
- ▶ Theory, Formulas & Diagrams to crack JEE
- ▶ Detailed high quality video lectures by experienced faculties
- ▶ JEE full preparation for Class XI & XII



**misostudy**  
connect smart learning

**JEE·NEET·AIIMS·CBSE·FOUNDATION**  
[www.misostudy.com](http://www.misostudy.com)

☎ 8929803804 (MON-FRI: 9am-6pm) [support@misostudy.com](mailto:support@misostudy.com)

MISO STUDY INDIA PVT. LTD.  
2ND FLOOR 65-A, OMPRO TOWER, KALU SARAI, NEW DELHI, DELHI 110016

Geometric Representation

Class 12 | Mathematics

# 03 Relations & Functions

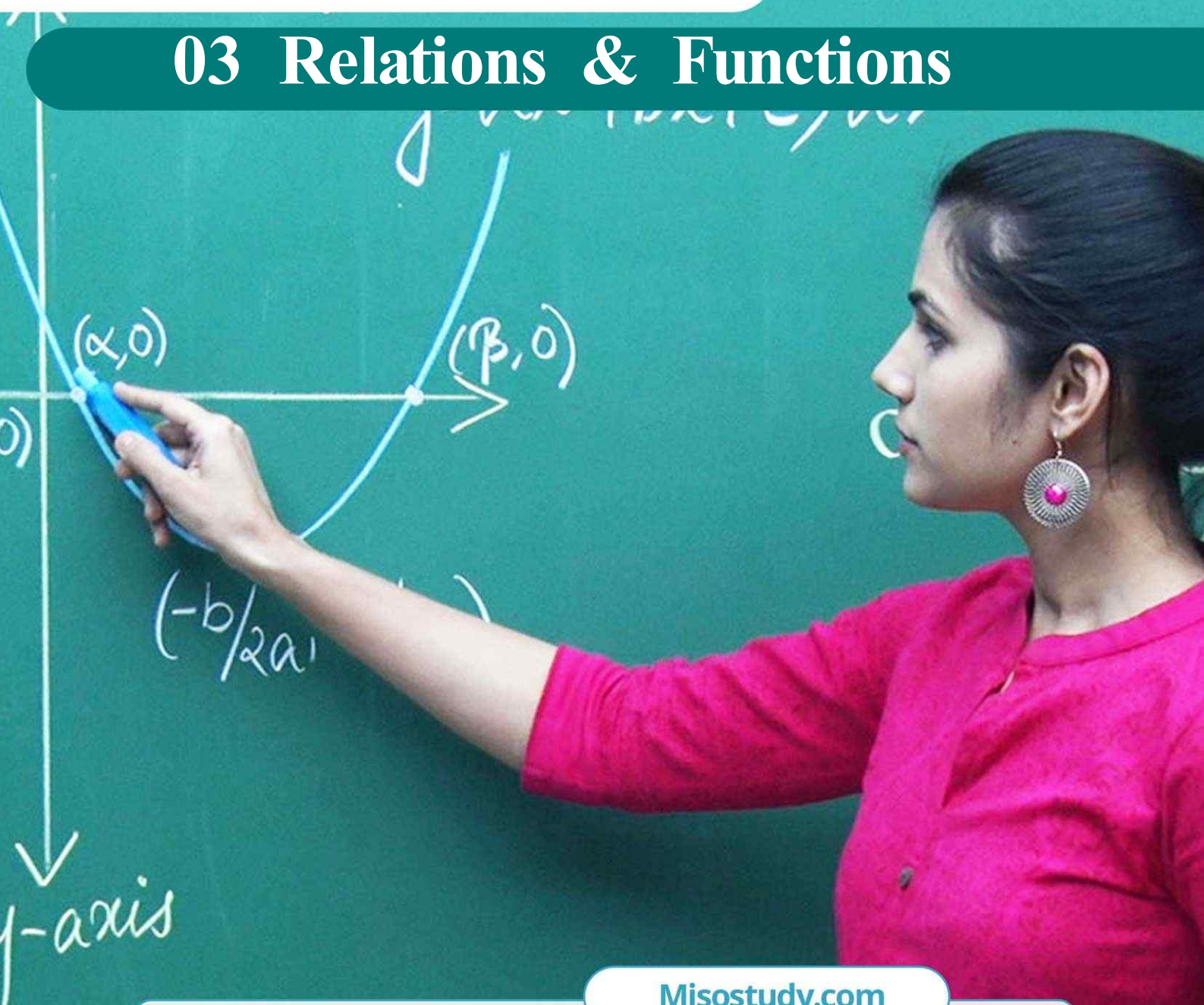

Misostudy.com



### Scientific eBook

This is a sample eBook. The eBook provides chapter-wise theories and examples, formulas, diagrams, and Exam pattern Problem-Solving of the full syllabus.



### Complete video lectures

The theory and Problem-Solving in this eBook provide specially designed the video lectures by experienced faculties. Get Free trial and preview on Misostudy.com.

## 01. Types of Relations

### (A) VOID, UNIVERSAL AND IDENTITY RELATIONS

#### Void Relation-

Let  $A$  be a set. Then,  $\phi \subseteq A \times A$  and so it is a relation on  $A$ . This relation is called the void or empty relation on set  $A$ .

#### Universal Relation-

Let  $A$  be a set. Then,  $A \times A \subseteq A \times A$  and so it is a relation on  $A$ . This relation is called the universal relation on  $A$ .

**NOTE**  It is to note here that the void relation and the universal relation on a set  $A$  are respectively the smallest and the largest relations on set  $A$ . Both the empty (or void) relation and the universal relation are sometimes. They are called trivial relations.

#### Identity Relation-

Let  $A$  be a set. Then, the relation  $I_A = \{(a, a) : a \in A\}$  on  $A$  is called the identity relation on  $A$ .

In other words, a relation  $I_A$  on  $A$  is called the identity relation i.e., if every element of  $A$  is related to itself only.

### (B) REFLEXIVE, SYMMETRIC, TRANSITIVE, ANTISYMMETRIC RELATIONS

#### Reflexive Relation-

A relation  $R$  on a set  $A$  is said to be reflexive if every element of  $A$  is related to itself.

Thus,  $R$  is reflexive  $\Leftrightarrow (a, a) \in R$  for all  $a \in A$ .

A relation  $R$  on a set  $A$  is not reflexive if there exists an element  $a \in A$  such that  $(a, a) \notin R$ .

#### Symmetric Relation-

A relation  $R$  on a set  $A$  is said to be a symmetric relation iff

$(a, b) \in R \Rightarrow (b, a) \in R$  for all  $a, b \in A$

i.e.  $aRb \Rightarrow bRa$  for all  $a, b \in A$ .

#### Transitive Relation-

Let  $A$  be any set. A relation  $R$  on  $A$  is said to be a transitive relation iff

$(a, b) \in R$  and  $(b, c) \in R$

$\Rightarrow (a, c) \in R$  for all  $a, b, c \in A$ .

i.e.  $aRb$  and  $bRc$

$\Rightarrow aRc$  for all  $a, b, c \in A$ .

#### Antisymmetric Relation-

Let  $A$  be any set. A relation  $R$  on set  $A$  is said to be an antisymmetric relation iff

$(a, b) \in R$  and  $(b, a) \in R \Rightarrow a = b$  for all  $a, b \in A$

**NOTE**  It follows from this definition that if  $(a, b) \in R$  and  $(b, a) \notin R$ , then also  $R$  is an antisymmetric relation.

### (C) Equivalence Relation

A relation  $R$  on a set  $A$  is said to be an equivalence relation on  $A$  iff

- (i) it is reflexive i.e.  $(a, a) \in R$  for all  $a \in A$
- (ii) it is symmetric i.e.  $(a, b) \in R \Rightarrow (b, a) \in R$  for all  $a, b \in A$
- (iii) it is transitive i.e.  $(a, b) \in R$  and  $(b, c) \in R \Rightarrow (a, c) \in R$  for all  $a, b, c \in A$ .

## 02. Some Results on Relations

### RESULT 1

If  $R$  and  $S$  are two equivalence relations on a set  $A$ , then  $R \cap S$  is also an equivalence relation on  $A$ .

**OR**

The intersection of two equivalence relations on a set is an equivalence relation on the set.

### RESULT 2

The union of two equivalence relations on a set is not necessarily an equivalence relation on the set.

### RESULT 3

If  $R$  is an equivalence relation on a set  $A$ , then  $R^{-1}$  is also an equivalence relation on  $A$ .

**OR**

The inverse of an equivalence relation is an equivalence relation.

## 03. Kinds of Functions

### ONE-ONE FUNCTION (INJECTION)

A function  $f : A \rightarrow B$  is said to be a one-one function or an injection if different elements of  $A$  have different images in  $B$ .

Thus,  $f : A \rightarrow B$  is one-one

$$\Leftrightarrow a \neq b \Rightarrow f(a) \neq f(b) \text{ for all } a, b \in A$$

$$\Leftrightarrow f(a) = f(b) \Rightarrow a = b \text{ for all } a, b \in A$$

### Algorithm

- (i) Take two arbitrary elements  $x, y$  (say) in the domain of  $f$ .
- (ii) Put  $f(x) = f(y)$
- (iii) Solve  $f(x) = f(y)$ . If  $f(x) = f(y)$  gives  $x = y$  only, then  $f : A \rightarrow B$  is a one-one function (or an injection). Otherwise not.



- NOTE** (i) Let  $f : A \rightarrow B$  and let  $x, y \in A$ . Then,  $x = y \Rightarrow f(x) = f(y)$  is always true from the definition. But,  $f(x) = f(y) \Rightarrow x = y$  is true only when  $f$  is one-one.
- (ii) If  $A$  and  $B$  are two sets having  $m$  and  $n$  elements respectively such that  $m \leq n$ , then total number of one-one functions from  $A$  to  $B$  is  ${}^n C_m \times m!$ .

### MANY-ONE FUNCTION

A function  $f : A \rightarrow B$  is said to be a many-one function if two or more elements of set  $A$  have the same image in  $B$ .

Thus,  $f : A \rightarrow B$  is a many-one function if there exist  $x, y \in A$  such that  $x \neq y$  but  $f(x) = f(y)$ .

**NOTE** In other words,  $f : A \rightarrow B$  is many-one function if it is not a one-one function.

### ONTO FUNCTION (SURJECTION)

A function  $f : A \rightarrow B$  is said to be an onto function or a surjection if every element of  $B$  is the  $f$ -image of some element of  $A$  i.e., if  $f(A) = B$  or range of  $f$  is the co-domain of  $f$ .

Thus,  $f : A \rightarrow B$  is a surjection iff for each  $b \in B$ , there exists  $a \in A$  such that  $f(a) = b$ .

**INTO FUNCTION.** A function  $f : A \rightarrow B$  is an into function if there exists an element in  $B$  having no pre-image in  $A$ .

In other words,  $f : A \rightarrow B$  is an into function if it is not an onto function.

### Algorithm

Let  $f : A \rightarrow B$  be the given function.

- (i) Choose an arbitrary element  $y$  in  $B$ .
- (ii) Put  $f(x) = y$
- (iii) Solve the equation  $f(x) = y$  for  $x$  and obtain  $x$  in terms of  $y$ . Let  $x = g(y)$ .
- (iv) If for all values of  $y \in B$ , the values of  $x$  obtained from  $x = g(y)$  are in  $A$ , then  $f$  is onto. If there are some  $y \in B$  for which  $x$ , given by  $x = g(y)$ , is not in  $A$ . Then,  $f$  is not onto.

### BIJECTION (ONE-ONE ONTO FUNCTION)

A function  $f : A \rightarrow B$  is a bijection if it is one-one as well as onto. In other words, a function  $f : A \rightarrow B$  is a bijection, if

- (i) it is one-one i.e.  $f(x) = f(y) \Rightarrow x = y$  for all  $x, y \in A$ .
- (ii) it is onto i.e. for all  $y \in B$ , there exists  $x \in A$  such that  $f(x) = y$ .

**REMARK** If  $A$  and  $B$  are two finite sets and  $f : A \rightarrow B$  is a function, then

- (i)  $f$  is an injection  $\Rightarrow n(A) \leq n(B)$
- (ii)  $f$  is an surjection  $\Rightarrow n(B) \leq n(A)$
- (iii)  $f$  is an bijection  $\Rightarrow n(A) = n(B)$ .

### HOMOGENEOUS FUNCTIONS

A function is said to be homogeneous with respect to any set of variables when each of its terms is of the same degree with respect to those variables.

For example  $5x^2 + 3y^2 - xy$  is homogeneous in  $x$  &  $y$ .

i.e.  $f(x, y)$  is a homogeneous function iff

$$f(tx, ty) = t^n f(x, y)$$

or  $f(x, y) = x^n g\left(\frac{y}{x}\right) = y^n h\left(\frac{x}{y}\right)$ , where  $n$  is the degree of homogeneity

e.g.  $f(x, y) = \frac{x - y \cos x}{y \sin x}$  is not a homogeneous function and

e.g.  $f(x, y) = \frac{x}{y} \ln \frac{y}{x} + \frac{y}{x} \ln \frac{x}{y}; \sqrt{x^2 - y^2} + x; x + y \cos \frac{y}{x}$  are homogeneous functions of degree one.

### BOUNDED FUNCTION

A function is said to be bounded if  $|f(x)| \leq M$ , where  $M$  is a finite quantity.

e.g.  $f(x) = \sin x$  is bounded in  $[-1, 1]$

### IMPLICIT & EXPLICIT FUNCTION

A function defined by an equation not solved for the dependent variable is called an IMPLICIT FUNCTION. For eg. the equation  $x^3 + y^3 = 1$  defines  $y$  as an implicit function. If  $y$  has been expressed in terms of  $x$  alone then it is called an EXPLICIT FUNCTION.

### ODD & EVEN FUNCTION

A function  $f(x)$  defined on the symmetric interval  $(-a, a)$

Iff  $f(-x) = f(x)$  for all  $x$  in the domain of ' $f$ ' then  $f$  is said to be an even function.

e.g.  $f(x) = \cos x; g(x) = x^2 + 3$

Iff  $f(-x) = -f(x)$  for all  $x$  in the domain of ' $f$ ' then  $f$  is said to be an odd function.

e.g.  $f(x) = \sin x; g(x) = x^3 + x$ .

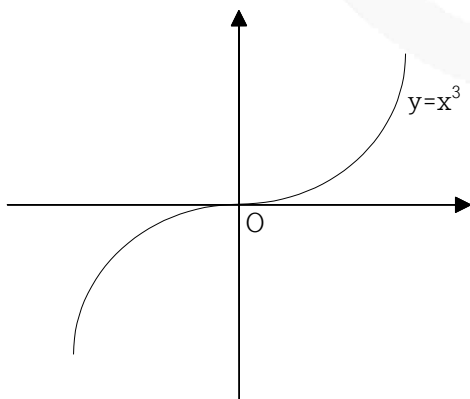

Odd function (Symmetric about origin)

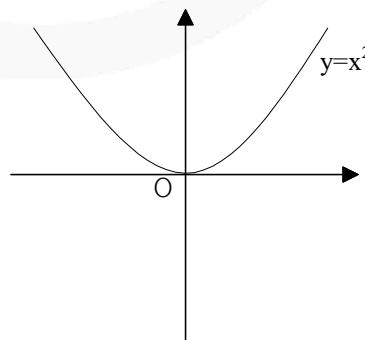

Even function (Symmetric about y-axis)

- NOTE**
- (a)  $f(x) - f(-x) = 0 \Rightarrow f(x)$  is even &  $f(x) + f(-x) = 0 \Rightarrow f(x)$  is odd.
  - (b) A function may neither be odd nor even.
  - (c) Inverse of an even function is not defined and an even function can not be strictly monotonic
  - (d) Every even function is symmetric about the  $y$ -axis & every odd function is symmetric about the origin.
  - (e) Every function can be expressed as the sum of an even & an odd function.

$$\text{e.g. } f(x) = \underbrace{\frac{f(x) + f(-x)}{2}}_{\text{EVEN}} + \underbrace{\frac{f(x) - f(-x)}{2}}_{\text{ODD}} \qquad 2^x = \underbrace{\frac{2^x + 2^{-x}}{2}}_{\text{EVEN}} + \underbrace{\frac{2^x - 2^{-x}}{2}}_{\text{ODD}}$$

- (f) The only function which is defined on the entire number line & is even and odd at the same time is  $f(x) = 0$ . Any non zero constant is even.
- (g) If  $f$  and  $g$  both are even or both are odd then the function  $f \cdot g$  will be even but if any one of them is odd then  $f \cdot g$  will be odd.

$f(x)$	$g(x)$	$f(x) + g(x)$	$f(x) - g(x)$	$f(x) \cdot g(x)$	$f(x) / g(x)$	$(g \circ f)(x)$	$(f \circ g)(x)$
odd	odd	odd	odd	even	even	odd	odd
even	even	even	even	even	even	even	even
odd	even	neither odd nor even	neither odd nor even	odd	odd	even	even
even	odd	neither odd nor even	neither odd nor even	odd	odd	even	even

**PERIODIC FUNCTION**

A function  $f(x)$  is called periodic if there exists a positive number  $T(T > 0)$  called the period of the function such that  $f(x + T) = f(x)$ , for all values of  $x$  within the domain of  $x$ .  
e.g. The function  $\sin x$  &  $\cos x$  both are periodic over  $2\pi$  &  $\tan x$  is periodic over  $\pi$ .

**Graphically :**

If the graph repeats at fixed interval then function is said to be periodic and its period is the width of that interval.

**PROPERTIES OF PERIODIC FUNCTION**

- (i)  $f(T) = f(0) = f(-T)$ , where ' $T$ ' is the period.
- (ii) Inverse of a periodic function does not exist.
- (iii) Every constant function is always periodic, with no fundamental period.
- (iv) If  $f(x)$  has a period  $p$ , then  $\frac{1}{f(x)}$  and  $\sqrt{f(x)}$  also has a period  $p$ .
- (v) if  $f(x)$  has a period  $T$  then  $f(ax + b)$  has a period  $\frac{T}{|a|}$ .

- (vi) If  $f(x)$  has a period  $T$  &  $g(x)$  also has a period  $T$  then it does not mean that  $f(x) + g(x)$  must have a period  $T$ . e.g.  $f(x) = |\sin x| + |\cos x|$ ;  $\sin^4 x + \cos^4 x$  has fundamental period equal to  $\frac{\pi}{2}$ .
- (vii) If  $f(x)$  and  $g(x)$  are periodic then  $f(x) + g(x)$  need not be periodic.  
e.g.  $f(x) = \cos x$  and  $g(x) = \{x\}$

#### 04. Composition of Uniformly Defined Functions

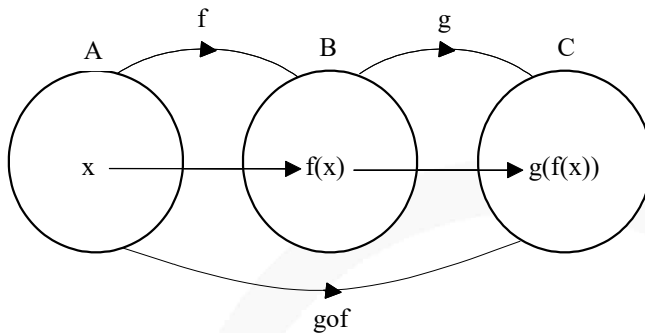

##### Definition:

Let  $f : A \rightarrow B$  and  $g : B \rightarrow C$  be two functions. Then a function  $gof : A \rightarrow C$  defined by

$$(gof)(x) = g(f(x)), \text{ for all } x \in A$$

is called the composition of  $f$  and  $g$ .

- NOTE** (i) It is evident from the definition that  $gof$  is defined only if for each  $x \in A$ ,  $f(x)$  is an element of  $B$  so that we can take its  $g$ -image. Hence, for the composition  $gof$  to exist, the range of  $f$  must be subset of the domain of  $g$ .
- (ii) It should be noted that  $gof$  exists iff the range of  $f$  is a subset of domain of  $g$ . Similarly,  $fog$  exists if range of  $g$  is a subset of domain of  $f$ .

#### PROPERTIES OF COMPOSITION OF FUNCTIONS

**RESULT 1** The composition of functions is not commutative i.e.  $fog \neq gof$ .

**RESULT 2** The composition of functions is associative i.e. if  $f, g, h$  are three functions such that  $(fog)oh$  and  $fo(goh)$  exist, then

$$(fog)oh = fo(goh)$$

**RESULT 3** The composition of two bijections is a bijection i.e. if  $f$  and  $g$  are two bijections, then  $gof$  is also a bijection.

**RESULT 4** Let  $f : A \rightarrow B$ . Then,  $foI_A = I_Bof = f$  i.e. the composition of any function with the identity function is the function itself.

**RESULT 5** Let  $f : A \rightarrow B, g : B \rightarrow A$  be two functions such that  $gof = I_A$ . Then,  $f$  is an injection and  $g$  is a surjection.

**RESULT 6** Let  $f : A \rightarrow B$  and  $g : B \rightarrow A$  be two function such that  $f \circ g = I_B$ . Then,  $f$  is a surjection and  $g$  is an injection.

**RESULT 7** Let  $f : A \rightarrow B$  and  $g : B \rightarrow A$  be two functions. Then,

- (i)  $g \circ f : A \rightarrow C$  is into  $\Rightarrow g : B \rightarrow C$  is onto
- (ii)  $g \circ f : A \rightarrow C$  is one-one  $\Rightarrow f : A \rightarrow B$  is one-one
- (iii)  $g \circ f : A \rightarrow C$  is onto and  $\Rightarrow g : B \rightarrow C$  is one-one  $\Rightarrow f : A \rightarrow B$  is onto
- (iv)  $g \circ f : A \rightarrow C$  is one-one and  $\Rightarrow f : A \rightarrow B$  is onto  $\Rightarrow g : B \rightarrow C$  is one-one.

## 05. Composition of Non-Uniformly Defined Functions

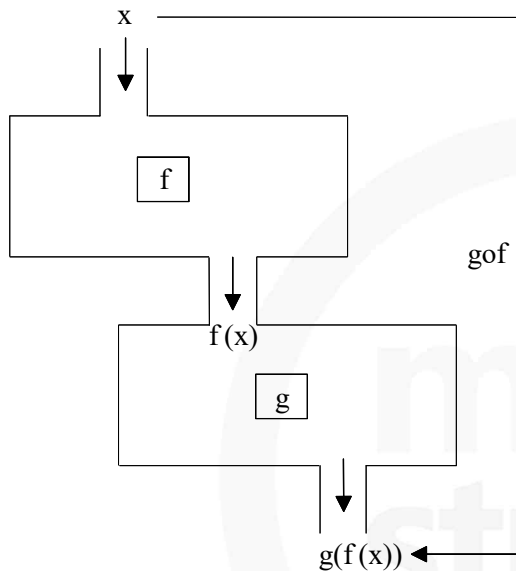

Piecewise or non-uniformly defined functions: Those functions whose domain is divided into two or more than two parts so that the function has different analytical formulae in different parts of its domain are called piecewise or non-uniformly defined functions. Also, a piecewise defined function is composed of branches of two or more functions.

Method: The method to find the composition of two non-uniformly defined functions is as follows-

Consider the functions as defined below

$$f(x) = \begin{cases} 2x-1; & 0 \leq x < 2 \\ x^2+1; & 2 \leq x \leq 4 \end{cases} \quad \& \quad g(x) = \begin{cases} x+1; & -1 \leq x < 1 \\ 2x; & 1 \leq x \leq 3 \end{cases}$$

Let us find the composite function  $f \circ g(x)$ . The following steps are involved.

**STEP 1:** Replace  $g(x)$  in the place of  $x$  in the definition of  $f(x)$ .

$$\text{i.e., } f(g(x)) = \begin{cases} 2g(x)-1; & 0 \leq g(x) < 2 \\ g(x)^2+1; & 2 \leq g(x) \leq 4 \end{cases}$$

**STEP 2:** Apply the definition of  $g(x)$  in the above step (1).

$$\Rightarrow f(g(x)) = \begin{cases} 2(x+1) - 1; & -1 \leq x < 1 & \& \quad 0 \leq x+1 < 2 \\ 2(2x) - 1; & 1 \leq x \leq 3 & \& \quad 0 \leq 2x < 2 \\ (x+1)^2 + 1; & -1 \leq x < 1 & \& \quad 2 \leq x+1 \leq 4 \\ (2x)^2 + 1; & 1 \leq x \leq 3 & \& \quad 2 \leq 2x \leq 4 \end{cases}$$

**STEP 3:** Take the intersection of domain and find the final definition.

$$\text{i.e., } f(g(x)) = \begin{cases} 2(x+1) - 1; & -1 \leq x < 1 \\ 2(2x) - 1; & x \in \{ \} \\ (x+1)^2 + 1; & x \in \{ \} \\ (2x)^2 + 1; & 1 \leq x \leq 2 \end{cases}$$

$$\Rightarrow f(g(x)) = \begin{cases} 2x+1; & -1 \leq x < 1 \\ 4x^2+1; & 1 \leq x \leq 2 \end{cases}$$

Thus, the domain of composite function  $f \circ g(x)$  is  $[-1, 2]$

## 06. Composition of Real Functions

### Definition:

Let  $f : D_1 \rightarrow R$  and  $g : D_2 \rightarrow R$  be two real functions. Then,

$$g \circ f : X = \{x \in D_1 : f(x) \in D_2\} \rightarrow R$$

and,

$$f \circ g : Y = \{x \in D_2 : g(x) \in D_1\} \rightarrow R$$

are defined as

$$g \circ f(x) : g(f(x)) \text{ for all } x \in X \text{ and } f \circ g(x) = f(g(x)) \text{ for all } x \in Y.$$

### REMARK

- (1) If  $\text{Range}(f) \subseteq \text{Domain}(g)$ , then  $g \circ f : D_1 \rightarrow R$  and if  $\text{Range}(g) \subseteq \text{Domain}(f)$ , then  $f \circ g : D_2 \rightarrow R$ .
- (2) For any two real functions  $f$  and  $g$ , it may be possible that  $g \circ f$  exists but  $f \circ g$  does not. In some cases, even if both exist, they may not be equal.
- (3) If  $\text{Range}(f) \cap \text{Domain}(g) = \phi$ , then  $g \circ f$  does not exist. In other words,  $g \circ f$  exists if  $\text{Range}(f) \cap \text{Domain}(g) \neq \phi$ .  
Similarly,  $f \circ g$  exists if  $\text{Range}(g) \cap \text{Domain}(f) \neq \phi$ .
- (4) If  $f$  and  $g$  are bijections, then  $f \circ g$  and  $g \circ f$  both are bijections.
- (5) If  $f : R \rightarrow R$  and  $g : R \rightarrow R$  to real functions, then  $f \circ g$  and  $g \circ f$  both exist.

## 07. Inverse of An Element

Let  $A$  and  $B$  be two sets and let  $f: A \rightarrow B$  be a mapping. If  $a \in A$  is associated to  $b \in B$  under the function  $f$ , then ' $b$ ' is called the  $f$  image of ' $a$ ' and we write it as  $b = f(a)$ . We also say that ' $a$ ' is the pre-image or inverse element of ' $b$ ' under  $f$  and we write  $a = f^{-1}(b)$ .

**NOTE**  The inverse of an element under a function may consist of a single element, two or more elements or no element depending on whether function is injective or many-one; onto or into.

If  $f$  is represented by Figure, then we find that

$$\begin{aligned} f^{-1}(b_1) &= \phi, f^{-1}(b_2) = a_4, \\ f^{-1}(b_3) &= \{a_1, a_2\}, f^{-1}(b_4) = a_3, \\ f^{-1}(b_5) &= \{a_5, a_6\}, f^{-1}(b_6) = \phi \\ \text{and, } f^{-1}(b_7) &= \phi \end{aligned}$$

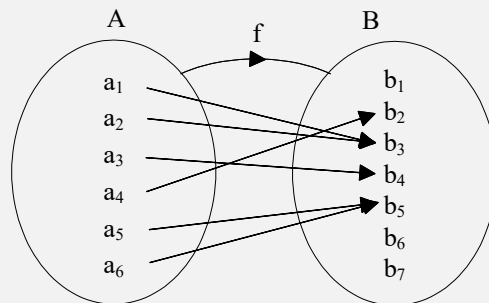

## 08. Inverse of A Function

### Definition:

Let  $f: A \rightarrow B$  be a bijection. Then a function  $g: B \rightarrow A$  which associates each element  $y \in B$  to a unique element  $x \in A$  such that  $f(x) = y$  is called the inverse of  $f$ .

$$\text{i.e., } f(x) = y \Leftrightarrow g(y) = x$$

The inverse of  $f$  is generally denoted by  $f^{-1}$

Thus, if  $f: A \rightarrow B$  is a bijection, then  $f^{-1}: B \rightarrow A$  is such that

$$f(x) = y \Leftrightarrow f^{-1}(y) = x$$

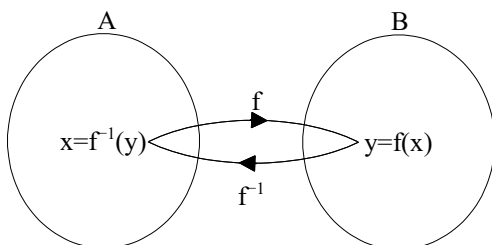

**Algorithm**

Let  $f: A \rightarrow B$  be a bijection. To find the inverse of  $f$  we follow the following steps:

STEP I Put  $f(x) = y$ , where  $y \in B$  and  $x \in A$ .

STEP II Solve  $f(x) = y$  to obtain  $x$  in terms of  $y$ .

STEP III In the relation obtained in step II replace  $x$  by  $f^{-1}(y)$  to obtain the required inverse of  $f$ .

**09. Properties of Inverse of a Function**

**RESULT 1** The inverse of a bijection is unique.

**RESULT 2** The inverse of a bijection is also a bijection.

**RESULT 3** If  $f: A \rightarrow B$  is a bijection and  $g: B \rightarrow A$  is the inverse of  $f$ , then  $f \circ g = I_B$  and  $g \circ f = I_A$ , where  $I_A$  and  $I_B$  are the identity function on the sets  $A$  and  $B$  respectively.

**RESULT 4** If  $f: A \rightarrow B$  and  $g: B \rightarrow C$  are two bijections, then  $g \circ f: A \rightarrow C$  is a bijection and  $(g \circ f)^{-1} = f^{-1} \circ g^{-1}$

**RESULT 5** If  $f: A \rightarrow B$  and  $g: B \rightarrow A$  be two functions such that  $g \circ f = I_A$  and  $f \circ g = I_B$ . Then,  $f$  and  $g$  are bijections and  $g = f^{-1}$ .

**RESULT 6** Let  $f: A \rightarrow B$  be an invertible function. Show that the inverse of  $f^{-1}$  is  $f$ , i.e.,  $(f^{-1})^{-1} = f$ .

**REMARK**

- (1) Sometimes  $f: A \rightarrow B$  is one-one but not onto. In such a case  $f$  is not invertible. But,  $f: A \rightarrow \text{Range}(f)$  is both one and onto. So, it is invertible and its inverse can be found.
- (2) Result 5 suggests us an alternative method to prove the invertibility of a function. It states that if  $f: A \rightarrow B$  and  $g: B \rightarrow A$  are two functions such that  $g \circ f = I_A$  and  $f \circ g = I_B$ , then  $f$  and  $g$  are inverse of each other. Result 5 suggests the following algorithm to find the inverse of an invertible function.

**Algorithm**

STEP I Obtain the function and check its bijectivity.

STEP II If  $f$  is a bijection, then it is invertible.

STEP III Use the formula for  $f(x)$  and replace  $x$  by  $f^{-1}(x)$  in it to obtain the LHS of  $f(f^{-1}(x)) = x$ .

Solve this equation for  $f^{-1}(x)$  to get  $f^{-1}(x)$ .



## 10. Permutation and Combinations Problems

### NUMBER OF RELATIONS AND FUNCTIONS

Given two finite sets  $A$  and  $B$  having  $n$  and  $m$  elements respectively, i.e.,  $n(A) = n$  and  $n(B) = m$ .

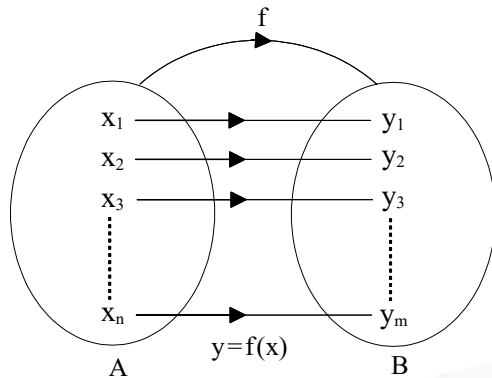

**Number of Relations:** No. of relations = Number of subsets of  $A \times B = 2^{n(A \times B)} = 2^{nm}$

**Number of Functions:** Since each element of set  $A$  can be mapped in  $m$  ways

$\Rightarrow$  Number of ways of mapping all  $n$  elements of  $A$

$$= \underbrace{(m \times m \times m \times \dots \times m)}_{n \times} \text{ ways} = m^n \text{ ways}$$

**Conclusion:**  $2^{nm} \geq m^n \forall m, n \in \mathbf{N}$

### NUMBER OF ONE-ONE FUNCTION (INJECTIVE):

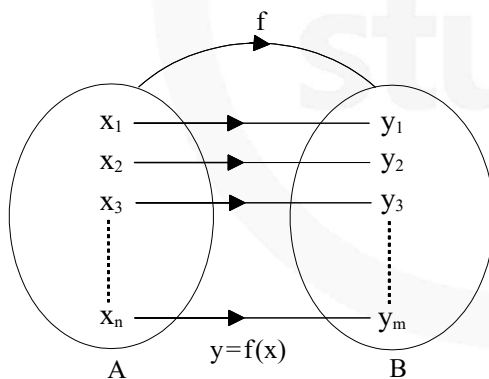

**Conclusion:**  ${}^m P_n \leq m^n$  (total number of functions).

### NUMBER OF NON-SURJECTIVE FUNCTIONS (INTO FUNCTIONS)

Number of into functions ( $N$ ) = Number of ways of distributing  $n$  different objects into  $m$  distinct boxes so that at least one box is empty.

$$\therefore N = \sum_{r=1}^m {}^m C_r (-1)^{r-1} (m-r)^n$$

**NUMBER OF SURJECTIVE FUNCTIONS**

Number of surjective functions = Total number of functions – number of into functions.

$$\begin{aligned}
 &= m^n - \sum_{r=1}^m {}^m C_r (-1)^{r-1} (m-r)^n \\
 &= m^n + \sum_{r=1}^m {}^m C_r (-1)^r (m-r)^n \\
 &= \sum_{r=0}^m {}^m C_r (-1)^r (m-r)^n
 \end{aligned}$$

**Conclusion:** In case when  $n(A) = n(B)$ , the onto functions will be bijection

Number of onto functions = Number of one-one functions

$$= \sum_{r=0}^n {}^n C_r (-1)^r (n-r)^n = n!$$

**REMARK**

- (1) If  $n(X) < n(Y)$ , then after mapping different elements of  $X$  to different elements of  $Y$ , we are left with at least one element of  $Y$  which is not related with any element of  $X$ , and hence, there will be no onto function from  $X$  to  $Y$ , i.e., all the functions from  $X$  to  $Y$  will be into.
- (2) If  $n(X) > n(Y)$ , then no injective functions can be formed from  $X$  to  $Y$  as in this case at least one element of  $Y$  has to be related to more than one element of  $X$ .
- (3) If  $f$  from  $X$  to  $Y$  is a bijective functions, then  $n(X) = n(Y)$

**Example**

A function  $f: A \rightarrow B$ , such that set “ $A$ ” and “ $B$ ” contain four elements each then find

- (i) Total number of functions
- (ii) Number of one-one functions
- (iii) Number of many one functions
- (iv) Number of onto functions
- (v) Number of into functions

**Sol.**

- (i) 1<sup>st</sup> element of  $A$  can have its image in 4 ways. Similarly, II<sup>nd</sup>, III<sup>rd</sup> and IV<sup>th</sup> can have 4 options for their image each. Hence number of functions =  $4^4$
- (ii) 4 different elements can be matched in  $4!$  ways
- (iii) Number of many-one functions  
= Total number of functions – number of one-one functions  
=  $4^4 - 4!$
- (iv) Since 4 elements in  $B$  are given hence each should be image of atleast one.  
So number of onto functions =  $4!$
- (v) Number of into functions =  $4^4 - 4!$

## 11. Functional Equations

**Example** If  $f(0) = 1, f(1) = 2$  &  $f(x) = \frac{1}{2}[f(x+1)+f(x+2)]$ , find the value of  $f(5)$ .

**Sol.**  $f(x+2) = 2f(x) - f(x+1)$   
 thus  $f(0+2) = f(2) = 2f(0) - f(1) = 2(1) - 2 = 0$   
 $f(3) = 2f(1) - f(2) = 2(2) - 0 = 4$   
 $f(4) = 2f(2) - f(3) = 0 - 4 = -4$   
 $f(5) = 2f(3) - f(4) = 2(4) - (-4) = 12$

## 12. Binary Operation

### DEFINITION

A binary operation  $*$  on a set  $A$  is a function from set  $A \times A$  to  $A$  itself. Thus,  $*$  associates each pair  $(a_1, a_2) \in A \times A$  to a unique element  $(a_1 * a_2)$  of  $A$ . Thus, domain of a binary operation defined on set  $A$  is  $A \times A$  and co-domain is  $A$ . Range is subset of  $A$ .

For example,

Let  $A = \{-1, 0, 1\}$  and  $*$  is a function defined as  $*$   $(a_1, a_2) = a_1 \cdot a_2; a_1, a_2 \in A$

Now we observe,

- $*$   $(-1, -1) = (-1) \cdot (-1) = 1 \in A;$
- $*$   $(-1, 0) = (-1) \cdot (0) = 0 \in A;$
- $*$   $(-1, 1) = (-1) \cdot (1) = -1 \in A;$
- $*$   $(1, 1) = (1) \cdot (1) = 1 \in A;$
- $*$   $(1, 0) = (1) \cdot (0) = 0 \in A;$
- $*$   $(0, 0) = (0) \cdot (0) = 0 \in A;$

Thus,  $*$  operated to every pair  $(a_1, a_2) \in A \times A$  gives us a unique element of  $A$ .

Hence, the function  $*$  defined in the above example is a binary operation on set  $A$ .

### PROPERTIES OF BINARY OPERATION $*$ ON A SET $A$

- (i) **Closure Property:** Since binary operation  $*$  on a set  $A$  is a function from  $A \times A$  to  $A$ , it obeys closure law, i.e.,  $a * b \in A \forall a, b \in A$ . Also we say that  $A$  is closed with respect to binary operation  $*$ .
- (ii) **Associativity:** Binary operation  $*$  on a set  $A$  is said to be associative, if  $a * (b * c) = (a * b) * c \forall a, b, c \in A$ .
- (iii) **Commutativity:** Binary operation  $*$  on a set  $A$  is said to be commutative if  $a * b = b * a \forall a, b \in A$ .
- (iv) **Existence of Identity:** An element  $e \in A$  is said to be an identity element of set  $A$  with respect to binary operation  $*$  if  $a * e = e * a = a \forall a \in A$ . For example, '+' is a binary operation on set of integer  $\mathbb{Z}$ . Also  $0 \in \mathbb{Z}$  and  $x + 0 = 0 + x = x \forall x \in \mathbb{Z} \Rightarrow 0$  is an identity element of set of integers  $\mathbb{Z}$  with respect to binary operation '+' (addition). Also 0 is called additive identity of set of integers.

- (v) **Existence of Inverse:** An element  $b \in A$  is said to be inverse of element  $a \in A$  with respect to binary operation  $*$  if  $a * b = e = b * a$ ; where  $e$  is the identity element of  $A$  with respect to binary operation  $*$ . And we denote  $b = a^{-1}$ .

- REMARK**
1. If a binary operation  $*$  on set  $A$  is associative and identity element exists in  $A$  and every element of  $A$  is invertible, then  $A$  is said to be a Group with respect to binary operation  $*$ .
  2. In addition to properties given in remark (1) if  $*$  is commutative, then set  $A$  is said to be an Abelian Group with respect to binary operation  $*$ .
  3. If  $b = a^{-1}$ , then  $a = b^{-1}$ .
  4. Identity element if exists is unique.
  5. Inverse of an element if exists is unique provided  $*$  is associative.
  6. Number of binary operations that can be defined on a set  $A$  containing  $n$  number of elements is  $(n)^{2n}$ .

### 13. Some Graphical Transformation

Consider the graph  $y = f(x)$  shown alongside.

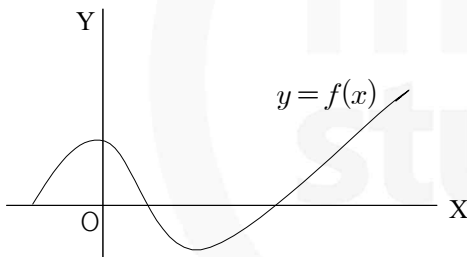

- (i) Graph of  $y - \beta = f(x - \alpha)$  is drawn by shifting the origin to  $(\alpha, \beta)$  & then translating the graph of  $y = f(x)$  w.r.t. new axes

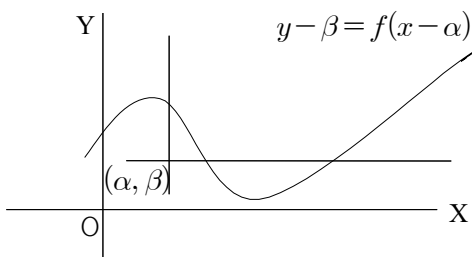

- (ii) The graph of  $y = -f(x)$  is the mirror image of  $f(x)$  in  $X$ -axis.

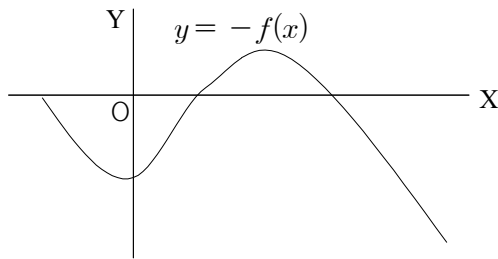

- (iii)  $y = |f(x)|$  is mirror image of negative portion of  $y = f(x)$  in  $X$ -axis.

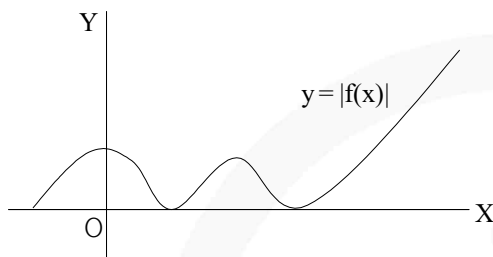

- (iv)  $y = f(|x|)$  is drawn by taking the mirror image of positive  $x$ -axis graph in  $y$ -axis.

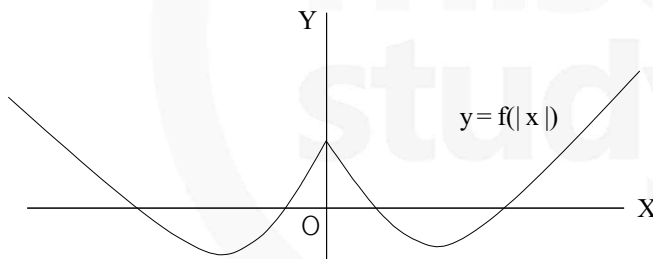

- (v) The graph of  $|y| = f(x)$  is drawn by deleting those portions of the graph  $y = f(x)$  which lie below the  $X$ -axis and then taking the mirror image of the remaining portion in the  $X$ -axis, as shown alongside.

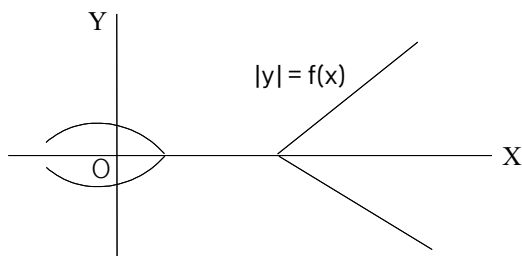

(vi)  $x = f(y)$  is drawn by taking mirror image of  $y = f(x)$  in the line  $y = x$ .

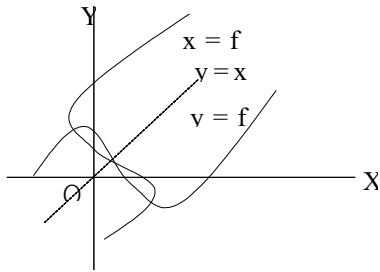

(vii)  $y = f(-x)$  is drawn by taking the mirror image of  $y = f(x)$  in  $Y$ -axis,

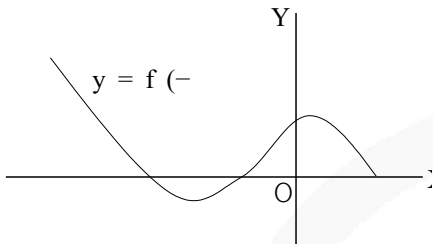

### 14. Transformation of Graphs

★ **GRAPH OF  $y = f(x) + k$  :**

Graph of  $y = f(x) + k$  can be obtained by translating graph of  $f(x)$  by  $|k|$  unit along  $y$ -axis in the direction same as sign of  $k$ , i.e., upward when  $k > 0$  and downward when  $k < 0$ .

**REASON:**

This is because each out put of the function is added by  $k$ . Therefore, each point of graph shifts vertically by  $k$  unit.

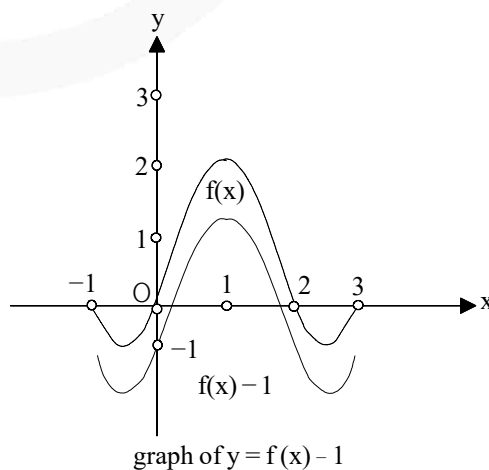
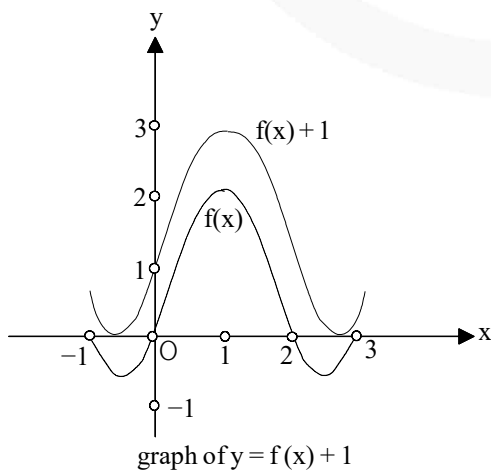

★ **GRAPH OF  $y = f(x + k)$  :**

Graph of  $y = f(x + k)$  can be obtained by translating graph of  $y = f(x)$  by  $|k|$  units in the direction opposite to the sign of  $k$  along  $x$ -axis. That is, a addition and subtraction to independent variable leads to horizontal shift.

**REASON:**

As because each output  $f(x)$  of the original function is obtained by the transformed function  $f(x + k)$  at the input  $x - k$ .

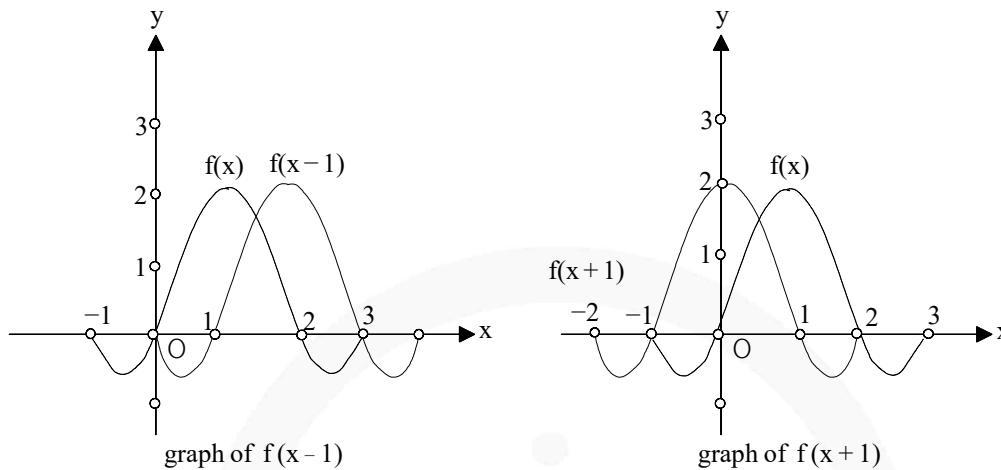

★ **GRAPH OF  $y = k(f(x))$  :**

Graph of  $y = k(f(x))$  can be obtained by vertically stretching or contracting the graph of  $f(x)$  depending on the value of  $k$ .

**REASON:**

It is because each output of the obtained function becomes  $k$  times that of the original function. Hence, due to this transformation no stretching/compression is produce along  $x$ -axis.

**CASE I:** When  $0 < |k| < 1$

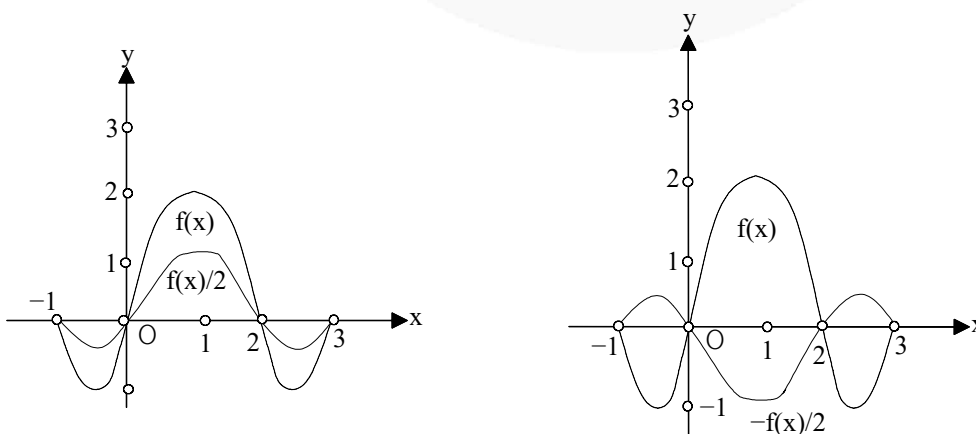

**CASE II:** When  $|k| > 1$

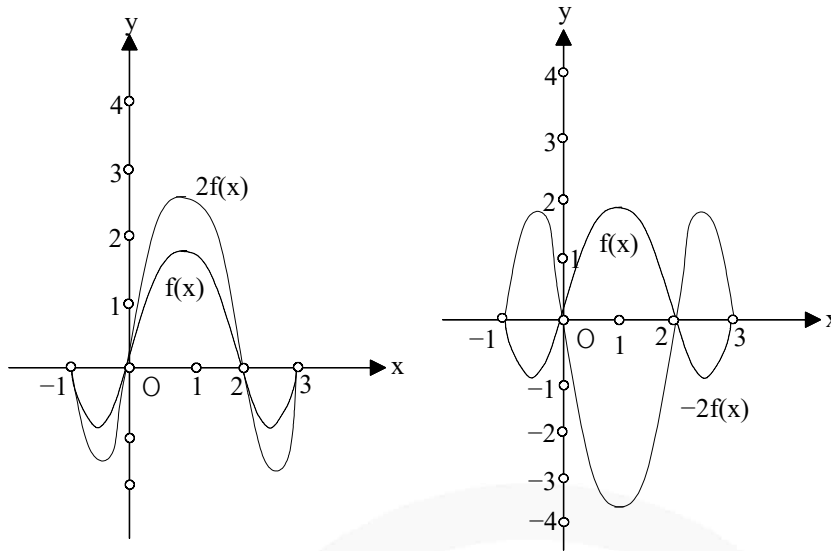

★ **GRAPH OF  $y = f(kx)$  :**

Graph of  $y = f(kx)$  can be obtained by compressing or stretching the graph of  $y = f(x)$  along  $x$ -axis towards  $y$ -axis or away from  $y$ -axis depending on the value of  $k$  as described below.

**CASE I:**

When  $|k| > 1$ , compressing the graph of  $f(x)$  horizontally towards  $y$ -axis.

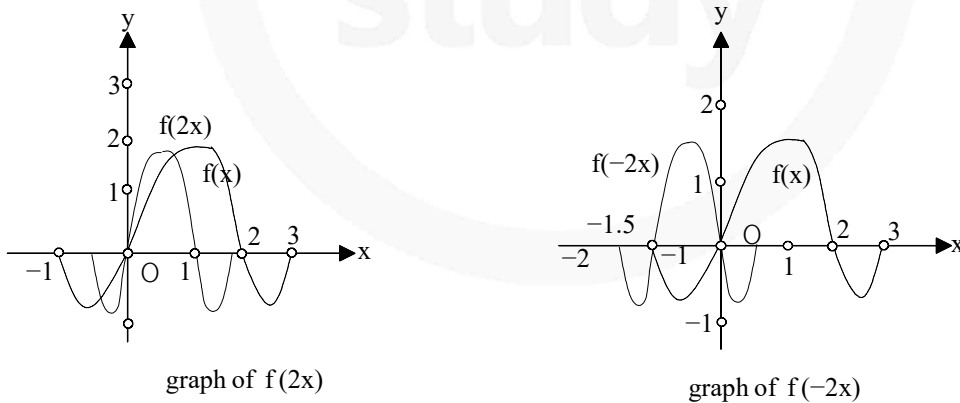



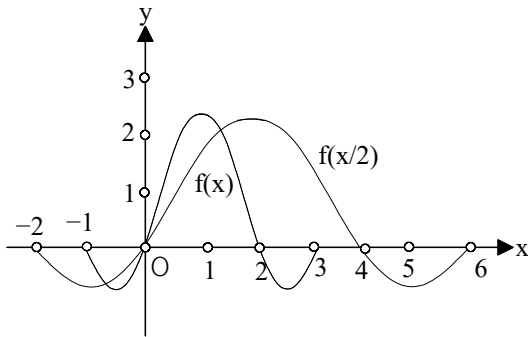

graph of  $f(x/2)$

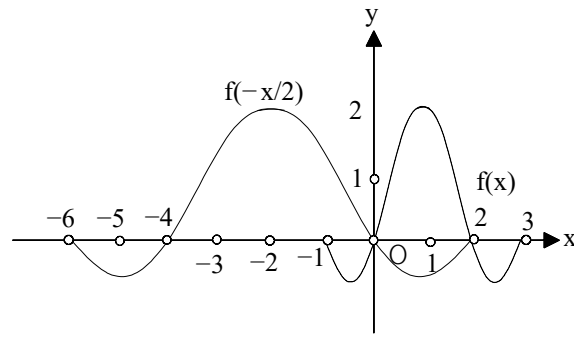

graph of  $f(-x/2)$

★ **GRAPH OF  $y = |f(x)|$  :**

Graph of  $y = |f(x)|$  can be obtained by reflecting the portion of the graph of  $f(x)$  laying below  $x$ -axis on  $x$ -axis as a mirror and keeping the portion of graph above  $x$ -axis as it is.

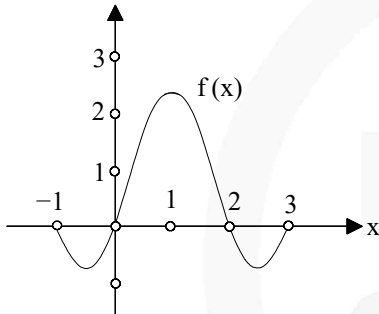

graph of  $f(x)$

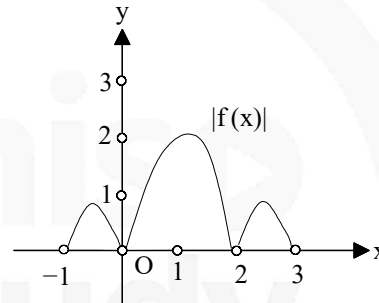

graph of  $|f(x)|$

★ **GRAPH OF  $y = f(|x|)$  :**

Graph of  $y = f(|x|)$  can be obtained by keeping the portion of graph of  $f(x)$  on right side of  $y$ -axis and replacing the portion of the graph of  $y = f(x)$  on left side of  $y$ -axis by the reflection of right graph on  $y$ -axis.

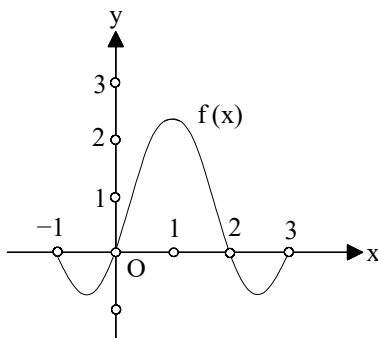

graph of  $f(x)$

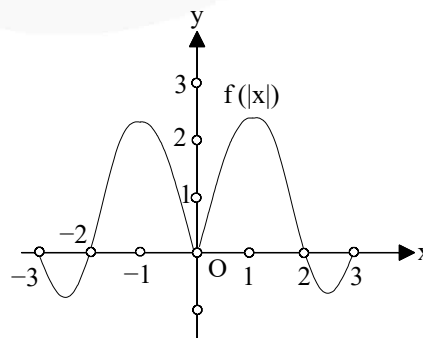

graph of  $f(|x|)$

★ **GRAPH OF  $y = f(|x|)$  :**

Graph of  $y = f(|x|)$  can be obtained by keeping the portion of graph of  $f(x)$  on right side of  $y$ -axis and replacing the portion of the graph of  $y = f(x)$  on left side of  $y$ -axis by the reflection of right graph on  $y$ -axis.

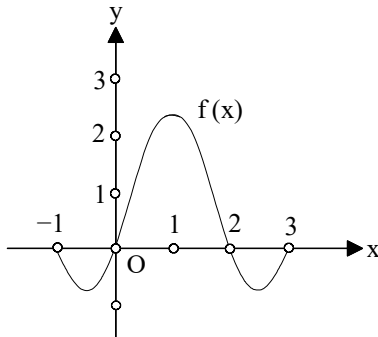

graph of  $f(x)$

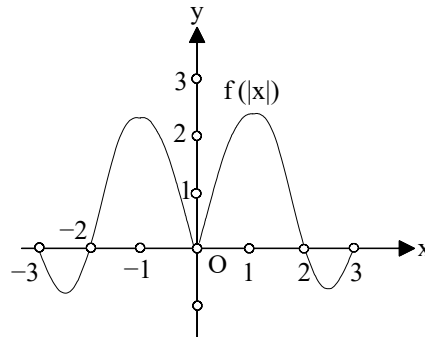

graph of  $f(|x|)$

★ **GRAPH OF  $y = |f(x)|$  can be obtained in two steps :**

**Step 1:** Using graph of  $y = f(x)$ , draw the graph of  $f|x|$ .

**Step 2:** Using graph of  $y = f|x|$ , draw the graph of  $y = |f|x||$ .

## JEE Main Pattern Exercise (1)

- Q1. The function  $f: R \rightarrow \left[-\frac{1}{2}, \frac{1}{2}\right]$  defined as  $f(x) = \frac{x}{1+x^2}$  is-
- invertible
  - injective but not surjective
  - surjective but not injective
  - neither injective nor surjective
- Q2. If  $f_k(x) = 1/k(\sin^k x + \cos^k x)$ , where  $x \in R$  and  $k \geq 1$ , then  $f_4(x) - f_6(x)$  is equal to-
- 1/6
  - 1/3
  - 1/4
  - 1/12
- Q3. Which of the following relations on  $R$  is an equivalence relation?
- $aR_1 b \Leftrightarrow |a| = |b|$
  - $aR_2 b \Leftrightarrow a \geq b$
  - $aR_3 b \Leftrightarrow a$  divides  $b$
  - $aR_4 b \Leftrightarrow a < b$
- Q4. Let  $E = \{1, 2, 3, 4\}$  and  $F = \{1, 2\}$ . Then, the number of onto functions from  $E$  to  $F$  is-
- 14
  - 16
  - 12
  - 8
- Q5. If  $g\{f(x)\} = |\sin x|$  and  $f\{g(x)\} = (\sin \sqrt{x})^2$ , then
- $f(x) = \sin^2 x, g(x) = \sqrt{x}$
  - $f(x) = \sin x, g(x) = |x|$
  - $f(x) = x^2, g(x) = \sin \sqrt{x}$
  - $f$  and  $g$  cannot be determined
- Q6. If  $S$  is defined on  $R$  by  $(x, y) \in S \Leftrightarrow xy \geq 0$ . Then  $S$  is-
- an equivalence relation
  - reflexive only
  - symmetric only
  - transitive only
- Q7. Let  $f(x) = \frac{\alpha x}{x+1}, x \neq -1$ . Then, for what value of  $\alpha$  is  $f[f(x)] = x$ ?
- $\sqrt{2}$
  - $-\sqrt{2}$
  - 1
  - 1

- Q8. If  $f(x) = \cos(\log x)$ , then  $f(x) \cdot f(y) - \frac{1}{2} \left[ f\left(\frac{x}{y}\right) + f(xy) \right]$  has the value
- (a)  $-1$
  - (b)  $\frac{1}{2}$
  - (c)  $-2$
  - (d) None of these
- Q9. Let  $S$  be the set of all real numbers & let  $R$  be a relation on  $S$  defined by  $aRb \Leftrightarrow |a-b| \leq 1$ . Then  $R$  is-
- (a) Reflexive & Symmetric but not Transitive
  - (b) Reflexive & Transitive but not Symmetric
  - (c) Symmetric & Transitive but not Reflexive
  - (d) an equivalence relation
- Q10. If  $f(x) = \sin x + \cos x$ ,  $g(x) = x^2 - 1$ , then  $g\{f(x)\}$  is invertible in the domain
- (a)  $\left[0, \frac{\pi}{2}\right]$
  - (b)  $\left[-\frac{\pi}{4}, \frac{\pi}{4}\right]$
  - (c)  $\left[-\frac{\pi}{2}, \frac{\pi}{2}\right]$
  - (d)  $[0, \pi]$



# Answer & Solution

---

## ANSWER

Q1	Q2	Q3	Q4	Q5
(c)	(b)	(d)	(a)	(c)
Q6	Q7	Q8	Q9	Q10
(a)	(d)	(a)	(c)	(d)

miso  
study

## JEE Advanced Pattern Exercise (1)

Q1. If  $y = f(x) = \frac{x+2}{x-1}$ , then-

- (a)  $x = f(y)$
- (b)  $f(1) = 3$
- (c)  $y$  increases with  $x$  for  $x < 1$
- (d)  $f$  is a rational function of  $x$

Q2. Which of the following functions is periodic?

- (a)  $f(x) = x - [x]$ , where  $[x]$  denotes the greatest integer less than or equal to the real number  $x$
- (b)  $f(x) = \sin(1/x)$  for  $x \neq 0, f(0) = 0$
- (c)  $f(x) = x \cos x$
- (d) None of the above

Q3. Given the relation on  $R = \{(a,b), (b,c)\}$  in the set  $A = \{a,b,c\}$ . Then, the minimum number of ordered pairs which added to  $R$  make it an equivalence relation is-

- (a) 5
- (b) 6
- (c) 7
- (d) 8

Q4. If  $f: [1, \infty) \rightarrow [2, \infty)$  is given by  $f(x) = x + \frac{1}{x}$ , then  $f^{-1}(x)$  equal.

- (a)  $\frac{x + \sqrt{x^2 - 4}}{2}$
- (b)  $\frac{x}{1+x^2}$
- (c)  $\frac{x - \sqrt{x^2 - 4}}{2}$
- (d)  $1 + \sqrt{x^2 - 4}$

Q5. Let  $f(x) = \sin\left[\frac{\pi}{6} \sin\left(\frac{\pi}{2} \sin x\right)\right]$  for all  $x \in R$  and  $g(x) = \frac{\pi}{2} \sin x$  for all  $x \in R$ . Let  $(f \circ g)(x)$  denotes  $f\{g(x)\}$  and  $(g \circ f)(x)$  denotes  $g\{f(x)\}$ . Then, which of the following is/are true?

- (a) Range of  $f$  is  $\left[-\frac{1}{2}, \frac{1}{2}\right]$
- (b) Range of  $f \circ g$  is  $\left[-\frac{1}{2}, \frac{1}{2}\right]$
- (c)  $\lim_{x \rightarrow 0} \frac{f(x)}{g(x)} = \frac{\pi}{6}$
- (d) There is an  $x \in R$  such that  $(g \circ f)(x) = 1$

Q6. Which of the following relations defined on  $Z$  is not an equivalence relation-

- (a)  $(x,y) \in S \Leftrightarrow x \geq y$
- (b)  $(x,y) \in S \Leftrightarrow x = y$
- (c)  $(x,y) \in S \Leftrightarrow x - y$  is a multiple of 3
- (d)  $(x,y) \in S \Leftrightarrow |x - y|$  is even

### 03 Relations & Functions

- Q7. If the function  $f: [1, \infty) \rightarrow [1, \infty)$  is defined by  $f(x) = 2^{x(x-1)}$ , then  $f^{-1}(x)$  is-
- (a)  $\left(\frac{1}{2}\right)^{x(x-1)}$
  - (b)  $\frac{1}{2}(1 + \sqrt{1 + 4 \log_2 x})$
  - (c)  $\frac{1}{2}(1 - \sqrt{1 + 4 \log_2 x})$
  - (d) not defined
- Q8. Let  $a, b, c \in \mathbb{R}$ . If  $f(x) = ax^2 + bx + c$  be such that  $a + b + c = 3$  and  $f(x+y) = f(x) + f(y) + xy$ ,  $\forall x, y \in \mathbb{R}$ , then  $\sum_{n=1}^{10} f(n)$  is equal to-
- (a) 330
  - (b) 165
  - (c) 190
  - (d) 255
- Q9. If  $A = \{1, 2, 3\}$  then the no. of equivalence relation containing (1,2) is-
- (a) 1
  - (b) 2
  - (c) 3
  - (d) 8
- Q10. Let  $f$  be a one-one function with domain  $\{x, y, z\}$  and range  $\{1, 2, 3\}$ . It is given that exactly one of the following statements is true and the remaining two are false  
 $f(x) = 1, f(y) \neq 1, f(z) \neq 2$ . Then  $f^{-1}(1) =$
- (a)  $x$
  - (b)  $y$
  - (c)  $z$
  - (d) None of these



# Answer & Solution

## ANSWER

Q1	Q2	Q3	Q4	Q5
(a), (d)	(a)	(a), (c)	(a)	(a), (b), (c)
Q6	Q7	Q8	Q9	Q10
(a)	(b)	(a)	(c)	(b)

miso  
study