

JEE

CHEMISTRY

- ▶ Specially designed eBook for complete JEE syllabus
- ▶ JEE preparation strategy & direction, speedy revision
- ▶ Chapter-wise important Problem-Solving
- ▶ Theory, Formulas & Diagrams to crack JEE
- ▶ Detailed high quality video lectures by experienced faculties
- ▶ JEE full preparation for Class XI & XII



misostudy
connect smart learning

JEE·NEET·AIIMS·CBSE·FOUNDATION
www.misostudy.com

☎ 8929803804 (MON-FRI: 9am-6pm) support@misostudy.com

MISO STUDY INDIA PVT. LTD.
2ND FLOOR 65-A, OMPRO TOWER, KALU SARAI, NEW DELHI, DELHI 110016

Class 11 | Chemistry

02 Mole Concept

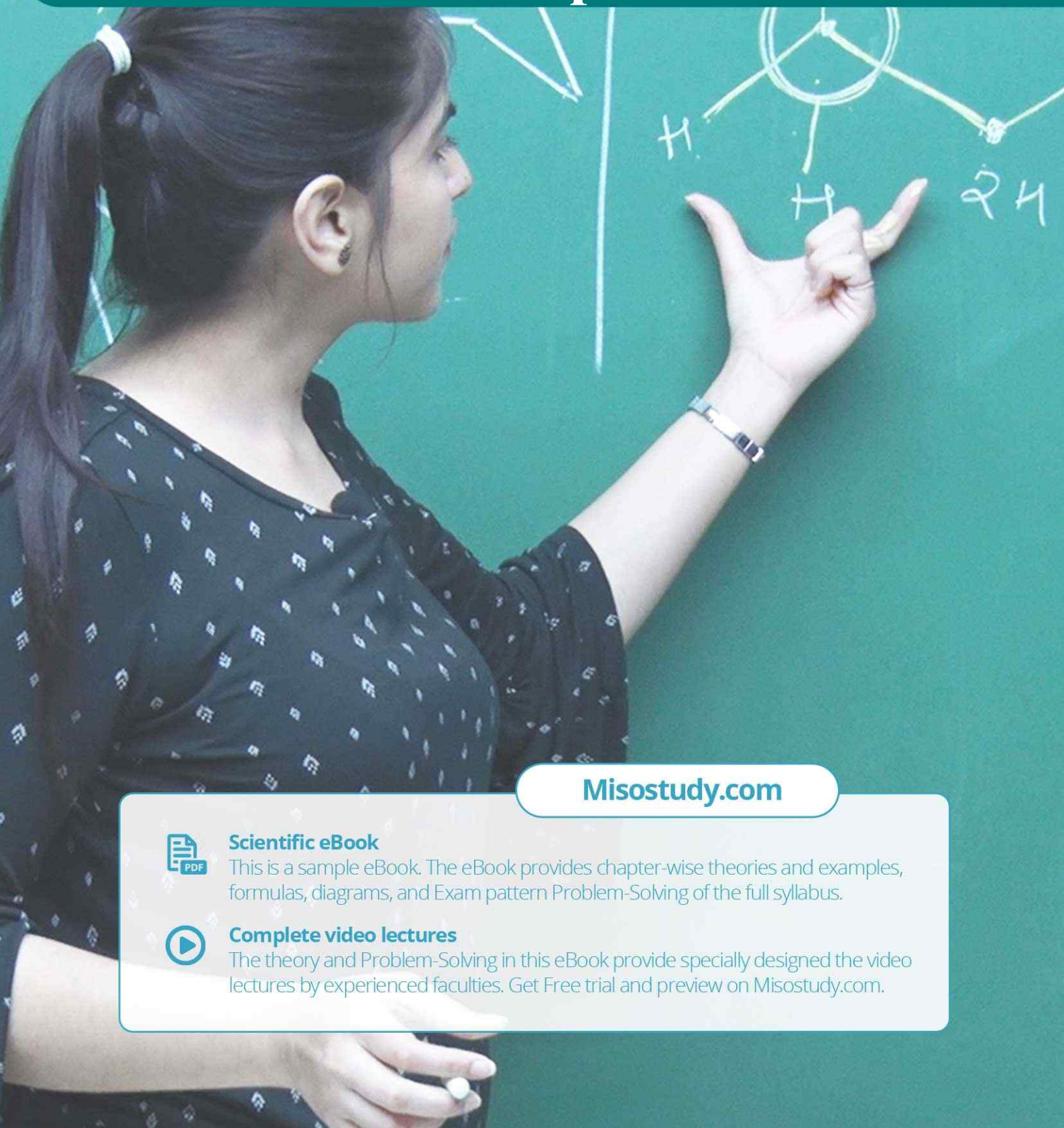

Misostudy.com



Scientific eBook

This is a sample eBook. The eBook provides chapter-wise theories and examples, formulas, diagrams, and Exam pattern Problem-Solving of the full syllabus.



Complete video lectures

The theory and Problem-Solving in this eBook provide specially designed the video lectures by experienced faculties. Get Free trial and preview on Misostudy.com.

01. Classification of matter

Chemistry deals with the composition, structure and properties of matter. These aspects can be best described and understood in terms of basic constituents of matter: **atoms** and **molecules**. That is why chemistry is called the science of atoms and molecules.

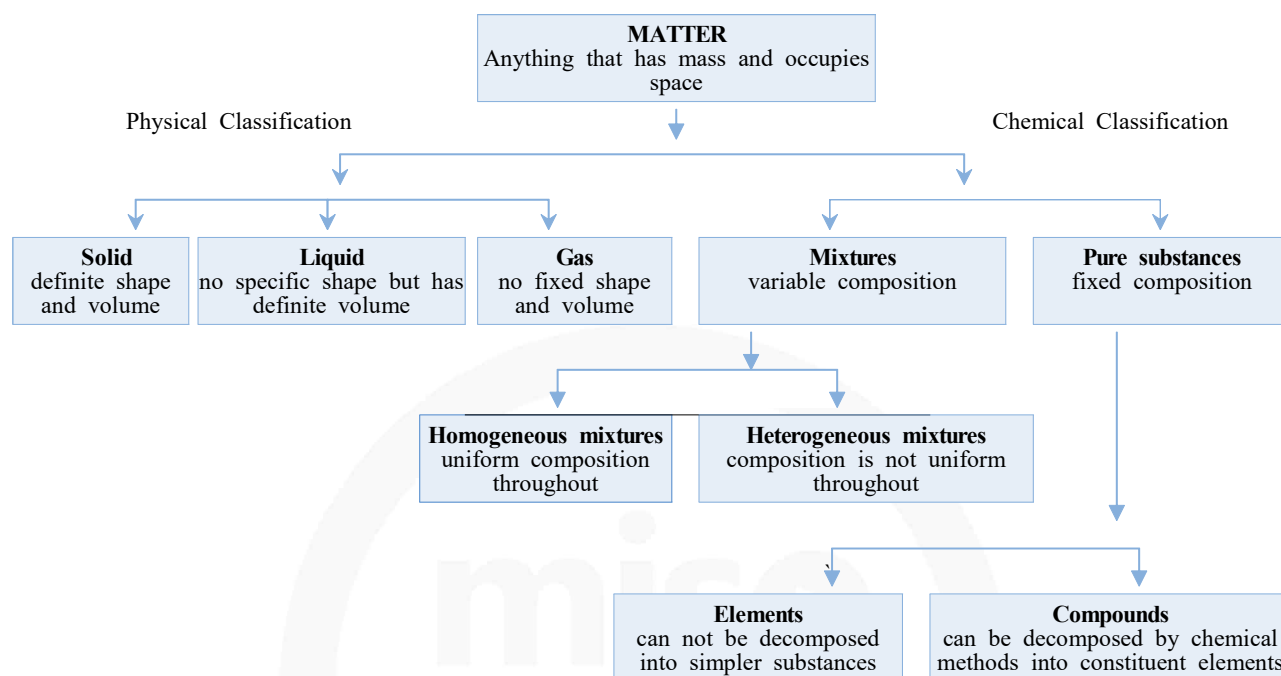

Matter

The thing which occupy space and have mass, which can be felt by our five sense is called as matter. Matter is further classified into two categories :

- Physical classification
- Chemical classification

02. Prefixed Used With Units

The S.I. system recommends the multiples such as 10^3 , 10^6 , 10^9 etc. and fraction such as 10^{-3} , 10^{-6} , 10^{-9} etc. i.e. the powers are the multiples of 3. These are indicated by special prefixes. These along with some other fractions or multiples in common use, along with their prefixes are given below in Table and illustrated for length (m).

※TABLE : SOME COMMONLY USED PREFIXES WITH THE BASE UNIT

Prefix	Symbol	Multiplication Factor	Example
deci	d	10^{-1}	1 decimetre (dm) = 10^{-1} m
centi	c	10^{-2}	1 centimetre (cm) = 10^{-2} m
milli	m	10^{-3}	1 millimetre (mm) = 10^{-3} m
micro	μ	10^{-6}	1 micrometre (μm) = 10^{-6} m
nano	n	10^{-9}	1 nanometre (nm) = 10^{-9} m
pico	p	10^{-12}	1 picometre (pm) = 10^{-12} m
femto	f	10^{-15}	1 femtometre (fm) = 10^{-15} m
atto	a	10^{-18}	1 attometre (am) = 10^{-18} m
deka	da	10^1	1 dekametre (dam) = 10^1 m
hecto	h	10^2	1 hectometre (hm) = 10^2 m
kilo	k	10^3	1 kilometre (km) = 10^3 m
mega	M	10^6	1 megametre (Mm) = 10^6 m
giga	G	10^9	1 gigametre (Gm) = 10^9 m
tera	T	10^{12}	1 terametre (Tm) = 10^{12} m
peta	P	10^{15}	1 petametre (Pm) = 10^{15} m
exa	E	10^{18}	1 exametre (Em) = 10^{18} m

As volume is very often expressed in litres, it is important to note that the equivalence in S.I. units for volume is as under: 1 litre (1 L) = $1 \text{ dm}^3 = 1000 \text{ cm}^3$ and 1 millilitre (1 ml) = $1 \text{ cm}^3 = 1 \text{ cc}$

Example Convert 2 atm into cm of Hg.

Solution $2 \text{ atm} = 2 \times 76 \text{ cm of Hg} = 152 \text{ cm of Hg}$ {1 atmosphere = 76 cm of Hg}

03. Different types of masses

One mole

Avogadro's Number (N_A) = 6.023×10^{23} . It is the number of atoms present in exactly 12 g of (C^{12}) isotope.

Atomic Weight (A)

Atomic weight is the relative weight of one atom of an element with respect to a standard weight.

$$A = \frac{\text{Weight of one atom of an element}}{\frac{1}{12} \text{th part by weight of an atom of } (\text{C}^{12}) \text{ isotope}}$$

amu (atomic mass unit)

$$1 \text{ amu} = \frac{1}{12} \text{th part by weight of an atom of } (\text{C}^{12}) \text{ isotope}$$

$$= \frac{1}{N_A} g = 1.66 \times 10^{-24} g$$

Atomic weight (A) × amu = Absolute atomic weight.

NOTE  Atomic weight is a relative weight that indicates the relative heaviness of one atom of an element with respect to amu weight. Atomic weight has no unit because it is the ratio of weights. One mole of an amu = 1.00 g.

Change of Scale for Atomic Weight

If an amu is defined differently as $(1/x)$ th part by weight of an atom of (C^{12}) isotope rather $(1/12)$ th part then the atomic weight (A') can be derived as:

$$A' = A \left(\frac{x}{12} \right)$$

Where, A = conventional atomic weight

Molecular Weight (MW)

Like atomic weight, it is the relative weight of a molecule or a compound with respect to amu weight.

$$\text{Molecular Weight} = \frac{\text{Weight of one molecule of a compound}}{\frac{1}{12} \text{th part by weight of an atom of } C^{12} \text{ isotope}}$$

Gram Atomic, Gram Molecular Weight (M)

It is the weight of 1.0 mole (Avogadro's numbers) of atoms, molecules or ions in gram unit.

$M = A \text{ amu} \times \text{Avogadro number} = A \text{ gram}$ Hence, gram molecular weight (M) is numerically equal to the atomic weight or (molecular weight) in gram unit because 1.0 mole of amu is 1.0 g.

Example A piece of Cu contain 6.022×10^{24} atoms. How many mole of Cu atoms does it contain?

Solution No. of mole = $\frac{6.022 \times 10^{24}}{N_A} = \frac{6.022 \times 10^{24}}{6.022 \times 10^{23}} = 10 \text{ mole}$

04. Law of conservation of mass (Lavoisier-1774):

In any physical or chemical change, mass can neither be created nor be destroyed.

It means:

Total mass of the reactants = total mass of the products.

This relationship holds good when reactants are completely converted into products.

In case the reacting material are not completely consumed the relationship will be-

Total mass of the reactants = Total mass of the products + mass of unreacted reactants.

Example 1.7 gram of silver nitrate dissolved in 100 gram of water is taken. 0.585 gram of sodium chloride dissolved in 100 gram of water is added it and chemical reaction occurs. 1.435 gm of AgCl and 0.85 gm NaNO_3 are formed. Show that these results illustrate the law of conservation of mass.

02 Mole Concept

Solution

Total masses before chemical change
 = mass of AgNO_3 + mass of NaCl + mass of water
 = 1.70 + 0.585 + 200g
 = 202.285 g

Total masses after the chemical reaction
 = mass of AgCl + mass of AgNO_3 + mass of water
 = 1.435 + 0.85 + 200
 = 202.258 g

Then, in this chemical change
 Total masses of reactants = Total masses of product

05. Law of constant composition : [proust 1799]

A chemical compound always contains the same element combined together in fixed proportion by mass.

Example

1.08 gram of Cu wire was allowed to react with nitric acid. The resulting solution was dried and ignited when 1.35 gram of copper oxide was obtained. In another experiment 1.15 gram of copper oxide was heated in presence of Hydrogen yielding 0.92 gram of copper. Show that the above data are in accordance with law of constant composition?

Solution

% of "Cu" in copper oxide in 1st case = $\frac{1.08}{1.35} \times 100$
 = 80%

% of oxygen = 20%

% of "Cu" in copper oxide in 2nd case = $\frac{0.92}{1.15} \times 100$
 = 80%

% of oxygen = 20%

06. Law of multiple proportion : [Dalton 1806]

When two elements combine to form two or more compounds, the different masses of one element which combine with a fixed mass of the other element, bear a simple ratio to one another.

Example

Two compounds each containing only tin and oxygen had the following composition.

	Mass % of Tin	Mass % of oxygen
Compound A	78.77	21.23
Compound B	88.12	11.88

Show that these data illustrate the law of multiple proportion?

Solution

In compound A
 21.23 parts of oxygen combine with 78.77 parts of tin.
 1 part of oxygen combine with $\frac{78.77}{21.23} = 3.7$ parts of Sn.

In compound B

11.88 parts of oxygen combine with 88.12 parts of tin.

1 part of oxygen combine with $\frac{88.12}{11.88} = 7.4$ parts of tin.

Thus the mass of Tin in compound A and B which combine with a fixed mass of oxygen are in the ratio 3.7:7.4 or 1:2. This is a simple ratio. Hence the data illustrate the law of multiple proportion.

07. Law of reciprocal proportion : [Richter 1794]

When two different elements combine with the same mass of a third element, the ratio on which they do so will be same or simple multiple if both directly combined with each other.

Example

The % composition of NH_3 , H_2O and N_2O_3 is as given below:

$\text{NH}_3 \rightarrow 82.35\% \text{ N and } 17.65 \text{ H.}$

$\text{H}_2\text{O} \rightarrow 88.9\% \text{ O and } 11.1 \text{ H}$

$\text{N}_2\text{O}_3 \rightarrow 63.15\% \text{ O and } 36.85\% \text{ N}$

On the basis of above data prove the law of reciprocal proportion?

Solution

63.15 parts of oxygen combine with 36.85 parts of "N"

Therefore, 88.9 part of oxygen combine with $\left(\frac{36.85}{63.15} \times 88.9\right) = 51.87$ part of "Nitrogen"

Therefore ratio is $\frac{11.1}{11.1} : \frac{51.87}{11.1} = 1 : 4.67$

Now compare with the ratio of Nitrogen and Hydrogen in NH_3

$$\frac{17.65}{17.65} : \frac{82.35}{17.65} = 1 : 4.67$$

Hence the Law of reciprocal proportion is verified

08. Gay-Lussac's law of gaseous volumes [Gay-Lussac-1808]

When gases combined or produced in a chemical reaction, they do so in a simple ratio by volume provided all the gases are at same temperature and pressure.

09. Limiting Reagent

It is the reagent that is consumed completely during a chemical reaction. If the supplied mass ratio of reactants are not stoichiometric ratio, one of the reagent is consumed completely leaving parts of others unreacted. One that is consumed completely is known as limiting reagent.

'Limiting reagent determine the amount of product in a given chemical reaction'

Example

If 20 gm of CaCO_3 is treated with 20 gm of HCl , how many grams of CO_2 can be generated according to following reaction?

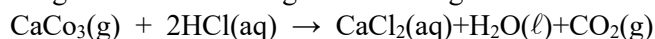
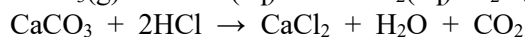
**Solution**

1 mole $\text{CaCO}_3 \rightarrow 2$ mole HCl

$\therefore 100 \text{ g CaCO}_3 \text{ combine} \rightarrow 2 \times 36.5 \text{ g HCl}$

$$\therefore 20 \text{ g} \rightarrow \frac{2 \times 36.5 \times 20}{100} = 14.6 \text{ HCl}$$

CaCO₃ completely consumes in the reaction and HCl is in excess.

Therefore,

CaCO₃ → Limiting reagent

HCl → Excess reagent

Now

100 g CaCO₃ given 1 mole CO₂ (44g CO₂)

20 g CaCO₃ will give $\frac{20 \times 40}{100} = 8 \text{ g CO}_2$

10. Percentage yield

In general, when a reaction is carried out on the laboratory we do not obtain the theoretical amount of product. The amount of product that is actually obtained is called the actual yield. Knowing the actual yield and theoretical yield, the % yield can be calculated by the following formula-

$$\text{Percentage yield} = \frac{\text{Actual yield}}{\text{Theoretical yield}} \times 100\%$$

Example

For the reaction

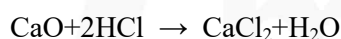

1.12 gram of CaO is reacted with excess of hydrochloric acid and 1.85 gm CaCl₂ is formed. What is the % yield of the reaction?

Solution

1 mole CaO gives 1 mole CaCl₂

56 g CaO gives 111 g CaCl₂

1.12 g CaO will give $\frac{111 \times 1.12}{56} \text{ g CaCl}_2 = 2.22 \text{ g CaCl}_2$

Now

$$\% \text{ yield} = \frac{\text{Actual yield}}{\text{Theoretical yield}} \times 100$$

Actual yield = 1.85 gm

Theoretical yield = 2.22 gm

$$\% \text{ yield} = \frac{1.85}{2.22} \times 100 = 83.33\%$$

11. Percentage Purity

Depending upon the mass of the product, the equivalent amount of reactant present can be determined with the help of given chemical equation. Knowing the actual amount of the reactant taken and the amount calculated with the help of a chemical equation, the purity can be determined, as

$$\text{Percentage purity} = \left[\frac{\text{Amount of reactant calculated from the chemical equation}}{\text{Actual amount of reactant taken}} \right] \times 100\%$$

02 Mole Concept

Example Calculate the amount of (CaO) in kg that can be produced by heating 200 kg lime stone that is 90% pure CaCO₃.

Solution CaCO₃ → CaO + CO₂
 1 mole CaCO₃ gives 1 mole CaO
 100 g CaCO₃ gives 56 g CaO
 $\left(\frac{200 \times 90 \times 1000}{100}\right)$ g CaCO₃ gives = $\frac{180000 \times 56}{100}$ g CaO
 = $\frac{1800 \times 56}{100}$ g CaO
 = $\frac{1008}{10}$ g CaO
 = 100.8 g CaO

12. Types of Average masses

Average Atomic Mass

Average atomic mass =

Let a sample contains n₁ mole of atomic mass M₁ and n₂ mole of atoms with atomic mass M₂ then

$$M_{av} = \frac{n_1 M_1 + n_2 M_2}{n_1 + n_2}$$

Average Molecular Mass

Average molecular mass =

Let a sample contains n₁ mole of molecules with molecular mass M₁ and n₂ mole of molecules with molecular mass M₂ ,then

$$M = \frac{n_1 M_1 + n_2 M_2}{n_1 + n_2}$$

Example Find the average atomic mass of a mixture containing 25% by mole Cl³⁷ and 75% by mole Cl³⁵?

Solution n₁ = 25 n₂ = 75 M₁ = 37 M₂ = 35

$$M_{av} = \frac{25 \times 37 + 75 \times 35}{25 + 75} = 35.5$$

13. Empirical & molecular formula

The empirical formula of a compound is a chemical formula showing the relative number of atoms in the simplest ratio. An empirical formula represents the simplest, whole number ratio of various atoms present in a compound.

The molecular formula gives the actual number of atoms of each element in a molecule. The molecular formula shows the exact number of different types of atoms present in a molecule of a compound. The molecular formula is an integral multiple of the empirical formula.

$$\text{i.e. molecular formula} = \text{empirical formula} \times n \quad \text{where } n = \frac{\text{molecular formula mass}}{\text{empirical formula mass}}$$

Example

An organic substance containing carbon, hydrogen and oxygen gave the following percentage composition.

C=40,684% ; H=5,085% ; and O=54,228%

The molecular weight of the compound is 118 g. Calculate the molecular formula of the compound.

Solution

Step-1 : To calculate the empirical formula of the compound.

Element	Sym bol	percent age of element	At. mass of element	Relative no. of atoms= $\frac{\text{Percentage}}{\text{At. mass}}$	Simplest atomic ratio	Simplest whole no. atomic ratio
Carbon	C	40.678	12	$\frac{40.678}{12} = 3.390$	$\frac{3.390}{3.389} = 1$	2
Hydrogen	H	5.085	1	$\frac{5.085}{1} = 5.085$	$\frac{5.085}{3.389} = 1.5$	3
Oxygen	O	54.228	16	$\frac{54.228}{16} = 3.389$	$\frac{3.389}{3.389} = 1$	2

\therefore Empirical Formula is $C_2 H_3 O_2$

Step-2 : To calculate the empirical formula mass. The empirical formula of the compound is $C_2 H_3 O_2$.

$$\text{Empirical formula mass} = (2 \times 12) + (3 \times 1) + (2 \times 16) = 59.$$

Step-3 : To calculate the value of 'n' $n = \frac{\text{Molecular mass}}{\text{Empirical formula mass}} = \frac{118}{59} = 2$

Step-4 : To calculate the molecular formula of the salt.

$$\text{Molecular formula} = n \times (\text{Empirical formula}) = 2 \times C_2H_3O_2 = C_4H_6O_4$$

Thus the molecular formula is $C_4H_6O_4$

14. Vapour Density

Some times in numericals molecular mass of volatile substance is not given, instead vapour density is given. Vapour density can be defined as

$$\text{V.D.} = \frac{\text{Density of gas at a given T and P}}{\text{Density of H}_2 \text{ at same T and P}}$$

$$\text{or, V.D.} = \frac{M_{\text{gas}}}{2}$$

$$M_{\text{gas}} = 2 \times \text{V.D.}$$

15. Eudiometry – Gas Analysis

The study of gaseous reactions is done in a eudiometer tube with the help of Gay-Lussac's law and Avogadro's law. Eudiometer tube is a closed graduated tube open at one end. The other end is a closed one which is provided with platinum terminals for passing electricity for electric spark, through the known volume of mixture of gases and known volume of oxygen gas. Volume of CO_2 formed is determined by absorbing in KOH solution, O_2 is determined by dissolving unreacted O_2 in alkaline pyrogallol and water vapours formed are determined by nothing contraction in volume caused due to cooling.

16. Avogadro's Law

In 1812, Amadeo Avogadro stated that samples of different gases which contain the same number of molecules (any complexity, size, shape) occupy the same volume at the same temperature and pressure.

For ideal gas at constant Temperature & Pressure, pressure is directly proportional to no. of moles

17. Some Absorbents of Gases

The absorbent which is used for specific gas is listed below

Absorbent	Gas or gases absorbed
Turpentine oil	O_3
Alkaline pyrogallol	O_2
Ferrous sulphate solution	NO
Heated magnesium	N_2
Heated palladium	H_2
Ammonical cuprous chloride	$\text{O}_2, \text{CO}, \text{C}_2\text{H}_2$ or $\text{CH} \equiv \text{CH}$
Copper sulphate solution	$\text{H}_2\text{S}, \text{PH}_3, \text{AsH}_3$
Conc. H_2SO_4	H_2O i.e., moisture, NH_3 .
NaOH or KOH solution	$\text{CO}_2, \text{NO}_2, \text{SO}_2, \text{X}_2$, all acidic oxides

02 Mole Concept

18. Volume Expansion and Contraction In The Eudiometer Tube

$$aA(g) + bB(g) \qquad cC(g) + dD(g)$$

$$\Delta n_g = \text{No. of gaseous products} - \text{No. of gaseous reactants} = (c+d) - (a+b)$$

- (a) If $\Delta n_g > 0$, then expansion will occur
 (b) If $\Delta n_g = 0$, No contraction/expansion (volume remains constant)
 (c) If $\Delta n_g < 0$, then contraction will occur

19. Assumptions

- (i) All gases are assumed to be ideal.
 (ii) Nitrogen gas formed during reaction will not react with any other gas.
 (iii) The volume of solids and liquids are negligible in comparison to the volume of gas.

20. General Reactions for Combustion of Organic Compounds

- (i) When an organic compound is hydrocarbon :

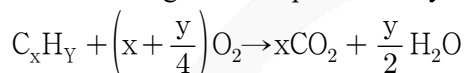

- (ii) When an organic compound contain carbon, hydrogen and oxygen :

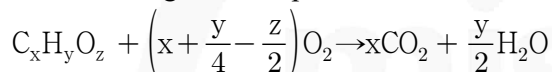

- (iii) When an organic compound contain carbon, hydrogen and nitrogen :

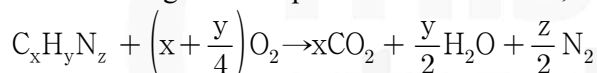

Example 10 ml of a mixture of CO, CH₄ and N₂, exploded with excess of oxygen, gave a contraction of 6.5 ml. There was a further contraction of 7 ml. when the residual gas was treated with KOH. What is the composition of the original mixture?

Solution CH₄ + 2O₂ → CO₂ + 2H₂O

$$x \text{ ml} \quad \frac{x}{2} \text{ ml} \qquad x \text{ ml}$$

$$y \text{ ml} \quad 2y \text{ ml} \qquad y \text{ ml}$$

$$\text{volume of oxygen used} = 2y + \frac{x}{2} \text{ ml}$$

$$\text{Total volume of all gases before combustion} = 10 + 2y + x/2$$

21. Percentage

Concentration of solution is the amount of solute dissolved in a known amount of the solvent or solution. The concentration of solution can be expressed in various ways as discussed below.

It refers to the amount of the solute per 100 parts if the solution. It can also be called as parts per hundred (pph). It can be expressed by any of following four methods:

- (i) **Weight by weight percentage (%w/w)** = $\frac{\text{Wt. of solute (g)}}{\text{Wt. of solution (g)}} \times 100$
e.g., 10%Na₂CO₃ solution w/w means 10 g of Na₂CO₃ is dissolved in 100 g of the solution. (It means 10 g Na₂CO₃ is dissolved in 90 of solvent)
- (ii) **Weight by volume percent (%w/v)** = $\frac{\text{Wt. of solute (g)}}{\text{Wt. of solution (cm}^3\text{)}} \times 100$
e.g., 10%Na₂CO₃ (w/v) means 10 g Na₂CO₃ is dissolved in 100 cm³ of solution
- (iii) **Volume by volume percent (%v/v)** = $\frac{\text{Volume of solute (cm}^3\text{)}}{\text{Volume of solution (cm}^3\text{)}} \times 100$
e.g., 10% ethanol (v/v) means 10 cm³ of ethanol dissolved in 100 cm³ of solution.
- (iv) **Volume by volume percent (%v/v)** = $\frac{\text{Vol. of solute}}{\text{Wt. of solution}} \times 100$
e.g., 10% ethanol (v/w) means 10 cm³ of ethanol dissolved in 100 g of solution.

Example

Concentrated nitric acid used as laboratory reagent is usually 69% by mass of nitric acid. Calculate the volume of the solution which contains 23 g nitric acid. The density of concentrated acid is 1.41 g cm⁻³.

Solution

69 g of HNO₃ in 100 g solution

given density = 1.41 g/cc

$$\text{density} = \frac{\text{mass}}{\text{volume}}$$

$$\text{volume} = \frac{\text{mass}}{\text{density}} = \frac{10000}{1.41} \text{ cc}$$

Now,

69 g HNO₃ is in $\frac{10000}{141}$ volume solution

$$23 \text{ g HNO}_3 \rightarrow \frac{23}{69} \times \frac{10000}{141} \text{ volume solution} = \mathbf{23.64 \text{ cm}^3}$$

22. Molarity (M)

The number of moles of solute dissolved in one litre solution is called its molarity.

$$\text{Molarity} = \frac{\text{Number of moles of solute}}{\text{volume of solution in litres}} = \frac{n}{V}$$

$$\text{weight of solute in gram} = \frac{\text{Molarity} \times \text{Volume of solution in mL} \times \text{molecular weight}}{1000}$$

$$\text{Molarity} = \frac{\text{Numbers of moles of solute} \times 1000}{\text{Volume of solution in mL}}$$

$$= \frac{\text{weight of solute in grams} \times 1000}{\text{Molecular weight} \times \text{Volume of solution in mL}}$$

$$= \frac{\text{strength of solution in gram/litre}}{\text{Molecular weight of solute}} = \text{Normality} \times \frac{\text{Equivalent weight of solute}}{\text{Molecular weight of solute}}$$

02 Mole Concept

Example A bottle of commercial sulphuric acid (density 1.787 g ml^{-1}) is labelled as 86% by weight. What is the molarity of acid?

Solution 86 g H_2SO_4 is in 100 g solution

Now

$$\begin{aligned} \text{density} &= \frac{\text{mass}}{\text{volume}} \\ 1.78 &= \frac{100}{V} \\ V &= \frac{10000}{1.78} = 56.18 \text{ ml.} \end{aligned}$$

Again

$$\begin{aligned} \text{molarity(M)} &= \frac{\text{no. of moles of } \text{H}_2\text{SO}_4 \times 1000}{\text{Volume of sol. in ml.}} \\ &= \frac{\left(\frac{86}{98}\right) \times 1000}{56.18} = \mathbf{15.62 \text{ M}} \end{aligned}$$

23. Molarity (m)

The number of moles or gram molecules of solute dissolved in 1000 gram of the solvent is called molality of the solution.

$$\text{Molality of a solution} = \frac{\text{Number of moles of solute}}{\text{Amount of solvent in kg}} = \frac{\text{Number of moles of solute} \times 1000}{\text{Amount of solvent in gram}}$$

It is independent of temperature.

24. Parts per million (ppm) and parts per billion (ppb)

When a solute is present in very small quantity, it is convenient to express the concentration in parts per million and parts per billion. It is the number of parts of solute per million (10^6) or per billion (10^9) parts of solution. It is independent of the temperature.

$$\text{ppm} = \frac{\text{Mass of solute component}}{\text{Mass of solution}}$$

$$\text{ppb} = \frac{\text{Mass of solute component}}{\text{Mass of solution}}$$

Example Calculate the parts per million of SO_2 gas in 250 ml water (density 1 g cm^{-3}) containing 5×10^{-4} g of SO_2 gas.

Solution Mass of SO_2 gas = 5×10^{-4} g; Mass of H_2O = Volume \times Density
= $250 \text{ cm}^3 \times 1 \text{ g cm}^{-3} = 250 \text{ g}$

$$\therefore \text{Parts per million of } \text{SO}_2 \text{ gas} = \frac{5 \times 10^{-4}}{250 \text{ g}} \times 10^6 = 2$$

25. Formality (F)

Formality of solution may be defined as the number of gram formula units of the ionic solute dissolved per litre of the solution. It is represented by **F**. Commonly, the term formality is used to express the concentration of the ionic solids which do not exist as molecules but exist as network of ions. A solution containing one gram formula mass of solute per liter of the solution has formality equal to one and is called **Formal solution**. It may be mentioned here that the formality of a solution changes with change in temperature.

$$\begin{aligned} \text{Formality(F)} &= \frac{\text{Number of gram formula units of solute}}{\text{Volume of solution in litres}} \\ &= \frac{\text{Mass of ionic solute (g)}}{\text{gram formula unit mass of solute} \times \text{Volume of solution (l)}} \end{aligned}$$

Example What will be the formality of KNO_3 solution having strength equal to 2.02 g per litre?

Solution Strength of $\text{KNO}_3 = 2.02 \text{ gL}^{-1}$ and g formula weight of $\text{KNO}_3 = 101 \text{ g}$

$$\therefore \text{Formality of } \text{KNO}_3 = \frac{\text{strength in } \text{g}^{\text{l}^{-1}}}{\text{g. formula wt. of } \text{KNO}_3} = \frac{2.02}{101} = \mathbf{0.02F}$$

26. Mole fraction (x)

The ratio of moles of one component to the total number of moles of all the components present in the solution, is called the mole fraction of that component.

Mole fraction of solute X_A is given by
$$X_A = \frac{n_A}{n_A + n_B}$$

Mole fraction of solute X_B is given by
$$X_B = \frac{n_B}{n_A + n_B}$$

where n_A is moles of solute A and n_B is moles of solvent B.

27. Mass Fraction

Mass fraction of a component in a solution is the mass of the component divided by the total mass of the solution. For a solution containing w_A gm of A and w_B gm of B.

$$\text{Mass fraction of A} = \frac{W_A}{W_A + W_B} \qquad \text{Mass fraction of B} = \frac{W_B}{W_A + W_B}$$

NOTE It may be noted that molarity, mole fraction, mass fraction etc. are preferred to molarity, normality, formality etc. Because the former involve the weights of the solute and solvent whereas the latter involve volumes of solutions. Temperature has no effect on weights but it has significant effect on volumes.

28. Equivalent Weight

Equivalent weight of an element is that part by weight which combines with 1.0 g of hydrogen or 8.0 g of oxygen or 35.5 g of chlorine.

$$(i) \text{ Equivalent weight of a salt (EW)} = \frac{\text{Molar mass}}{\text{Net positive (or negative) valency}}$$

e.g. Equivalent weight $\text{CaCl}_2 = \frac{M}{2}$, $\text{AlCl}_3 = \frac{M}{3}$, $\text{Al}_2(\text{SO}_4)_3 = \frac{M}{6}$

$$(ii) \text{ Equivalent weight of acids} = \frac{\text{Molar mass}}{\text{Basicity}}$$

e.g. Equivalent weight $\text{HCl} = M$ (basicity = 1); $\text{H}_2\text{SO}_4 = \frac{M}{2}$ (basicity = 2)

$$\text{H}_3\text{PO}_4 = \frac{M}{3} \text{ (basicity = 3)}$$

$$(iii) \text{ Equivalent weight of bases} = \frac{\text{Molar mass}}{\text{Acidity}}$$

e.g. Equivalent weight $\text{NaOH} = M$, $\text{Ca}(\text{OH})_2 = \frac{M}{2}$, $\text{Al}(\text{OH})_3 = \frac{M}{3}$

The number of gram-equivalents (Eq)

$$\text{Equivalent} = \frac{\text{Weight of compound}}{\text{Equivalent weight}} = \frac{w}{\text{Equivalent weight}}$$

Mole Equivalent Relationship In a given weight (w) of sample, number of moles (n) and number of equivalents (eq) are related as

$$n = \frac{w}{m} \text{ and } \text{Eq} = \frac{w}{\text{Equivalent weight}}$$

$$\frac{\text{Eq}}{n} = \frac{M}{\text{Equivalent weight}} = n - \text{factor}$$

n-factor For salt, it is valency, for acid it is basicity, for base it is acidity.

Normally/Molarity Relationship

$$N = \frac{\text{Eq}}{V} \text{ and } M = \frac{n}{V} \Rightarrow \frac{N}{M} = \frac{\text{Eq}}{n} = \frac{MW}{EW} = n - \text{factor}$$

29. Relation Between Molarity And Normality

$S = \text{Molarity} \times \text{molecular weight of solute}$ and $S = \text{Normality} \times \text{equivalent weight of solute}$.

So we can write

$\text{Molarity} \times \text{molecular weight of solute} = \text{Normality} \times \text{equivalent weight of solute}$.

$$\text{Normality} = \frac{\text{molarity} \times \text{molecular weight of solute}}{\text{equivalent weight of solute}} = \frac{\text{molarity} \times \text{molecular weight of solute}}{(\text{molecular weight of solute} / \text{valency factor})}$$

$\text{Normality} = \text{molarity} \times \text{valency factor}$

$$N = M \times n \quad ; \quad N > M$$

Example Calculate the molarity and molality of a solution of H_2SO_4 (sp. gr.=1.98) containing 27% H_2SO_4 by mass.
3.3 M, 3.77 M

Solution

$$\text{Vol of 100 g of 27\% H}_2\text{SO}_4 = \frac{\text{wt.}}{d} = \frac{100}{1.098} \text{ ml}$$

$$M_{\text{H}_2\text{SO}_4} = \frac{\text{wt./mol.wt.}}{\text{vol, of solution (litre)}} = \frac{27 \times 1.198 \times 1000}{98 \times 100} = 3.3 \text{ mol L}^{-1}$$

$$M_{\text{H}_2\text{SO}_4} = \frac{\text{wt./mol.wt.}}{\text{vol, of solvent (kg)}} = \frac{27 \times 1000}{(100-27) \times 98} = 3.77 \text{ mol Kg}^{-1}$$

30. Dilution Formula

If a concentrated solution is diluted, following formula work

$$M_1 V_1 = M_2 V_2$$

(M_1 and V_1 are the molarity and volumes before dilution and M_2 and V_2 are molarity and volumes after dilution)

31. Mixing of two or more solutions of different molarities

If two or more solutions of molarities (M_1, M_2, M_3, \dots) are mixed together, molarity of the

resulting

$$M = \frac{M_1 V_1 + M_2 V_2 + M_3 V_3 \dots}{V_1 + V_2 + V_3 \dots}$$

solution can be worked out as :

32. Strength of H₂O₂ solution

The strength of H₂O₂ in aqueous solution is expressed in the following two ways:

(i) Percentage strength

The mass of H₂O₂ present in 100 ml of the aqueous solution is termed as percentage strength. For example, a 25% solution (w/v) of H₂O₂ means that 25 grams of H₂O₂ are present in 100 ml of the solution.

(ii) Volume strength

Strength of the sample of H₂O₂ is generally expressed in terms of the volume of oxygen at 0°C and 1 atm that one volume of the sample of hydrogen peroxide gives on heating. The commercial samples are marked as '10 volume', '15 volume' or '20 volume'. 10 volume means that one volume of the sample of hydrogen peroxide gives 10 volumes of oxygen at 0°C and 1 atm. 1 ml of a 10 volume solution of H₂O₂ will liberate 10 ml of oxygen at 0°C and 1 atm.

33. Percentage labelling of oleum

Oleum is fuming sulphuric acid which contains extra SO₃ dissolved in H₂SO₄. To convert this extra SO₃ into H₂SO₄, water has to be added (SO₃+H₂O → H₂SO₄). The amount of sulphuric acid obtained when just sufficient water is added into 100 g of oleum so that all SO₃ present in it is converted into H₂SO₄ is called percentage labelling of oleum.

34. Relationship Between Different Concentration Terms

(i) $N = M \times n \text{ factor}$

(ii) $M = \frac{md}{1 + mM_2/1000}$

(iii) $m = \frac{1000 \times x_2}{x_1 M_1}$

(iv) $M = \frac{1000 \times dx_2}{x_1 M_1 + x_2 M_2}$

(v) $d = M \left(\frac{1}{m} + \frac{M_2}{1000} \right)$

(vi) Volume strength of H₂O₂ = $5.6 \times N = \frac{5.6 \times \text{Percentage strength}}{\text{Eq. wt. of H}_2\text{O}_2 (17)} \times 10$

(vii) Volume strength of H₂O₂ = $11.2 \times M = \frac{11.2 \times \text{Percentage strength} \times 10}{\text{Mol. wt. of H}_2\text{O}_2 (34)}$

(viii) In oleum labelled as (100 + x)%
% of free SO₃ = $\left(\frac{80 \times x}{18} \right)$ (w/w)

where N =Normality

M = Molarity

m = molarity

d = density of solution

M_2 = Molecular mass of solute

x_2 = Mole fraction of solute

x_1 = Mole fraction of solvent

M_1 = Molecular mass of solvent

d = Density of solution

misostudy

JEE Main Pattern Exercise (1)

- Q1. The ratio mass of oxygen and nitrogen of a particular gaseous mixture is 1:4. The ratio of number of their molecule is
- (a) 1:4
(b) 7:32
(c) 1:8
(d) 3:16
- Q2. The molarity of a solution obtained by mixing 750 mL of 0.5 M HCl with 250 mL of 2 M HCl will be
- (a) 0.875
(b) 1.00M
(c) 1.75M
(d) 0.0975M
- Q3. The normality of 0.3 M phosphorus acid (H_3PO_3) is
- (a) 0.1
(b) 0.9
(c) 0.3
(d) 0.6
- Q4. Dissolving 120 g of urea (mol. wt. 60) in 1000g of water gave a solution of density 1.15 g/mL. The molarity of the solution is
- (a) 1.78M
(b) 2.00M
(c) 2.05M
(d) 2.22M
- Q5. The mass of Mg_3N_2 produced if 48 gm of Mg metal is reacted with 34 gm NH_3 gas is
- $$\text{Mg} + \text{NH}_3 \rightarrow \text{Mg}_3\text{N}_2 + \text{H}_2$$
- (a) $\frac{200}{3}$
(b) $\frac{100}{3}$
(c) $\frac{400}{3}$
(d) $\frac{150}{3}$

02 Mole Concept

- Q6. What is the maximum amount of nitrogen dioxide that can be produced by mixing 4.2 gm of NO(g) and 3.2 gm of O₂(g)?
- 4.60g
 - 2.30g
 - 3.22g
 - 6.44g
- Q7. Which has maximum moles number of atoms?
- 24g of C(12)
 - 56g of Fe(56)
 - 27g of Al(27)
 - 108g of Ag(108)
- Q8. Equal volumes of 10% (v/v) of HCl solution. If density of pure NaOH is 1.5 times that of pure HCl then the resultant solution be.
- basic
 - neutral
 - acidic
 - can't be predicted.
- Q9. Given that the abundances of isotopes ⁵⁴Fe, ⁵⁶Fe and ⁵⁷Fe are 5%, 90% and 5%, respectively, the atomic mass of Fe is
- 55.85
 - 55.95
 - 55.75
 - 56.05
- Q10. 100 mL of 30% (w/v) NaOH solution is mixed with 100 mL 90% (w/v) NaOH solution. Find the molarity of final solution.
- 1.3
 - 13
 - 1/5
 - 15



Answer & Solution

ANSWER

Q1	Q2	Q3	Q4	Q5
(b)	(a)	(d)	(c)	(a)
Q6	Q7	Q8	Q9	Q10
(d)	(a)	(a)	(b)	(d)

miso
study

JEE Advanced Pattern Exercise (1)

- Q1. Dissolving 120 g of urea (mol. wt. 60) in 1000 g of water gave a solution of density 1.15 g/mL. The molarity of the solution is
- 1.78M
 - 2.00M
 - 2.05M
 - 2.22M

Paragraph question

FeSO₄ undergoes decomposition as

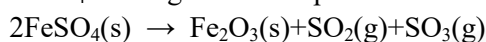

At 1 atm & 273 K if (7.6 gm) FeSO₄ is taken then.

- Q2. The volume occupied by the gases at 1 atm & 273K.
- 22.4 lit
 - 11.2 lit
 - 1.12 lit
 - 2.24 lit
- Q3. The average molar mass of the gaseous mixture.
- 72
 - 36
 - 48
 - 60

Assertion and Reason

- Both Statement I and Statement II are correct; Statement II is the correct explanation of Statement I
 - Both Statement I and Statement II are correct; Statement II is not the correct explanation of Statement I
 - Statement I is correct; Statement II is incorrect
 - Statement I is incorrect; Statement II is correct
- Q4. **Statement I** : Molality of pure ethanol is lesser than pure water.
Statement II : As density of ethanol is lesser than density of water.
[Given : $d_{\text{ethanol}} = 0.789 \text{ gm/ml}$; $d_{\text{water}} = 1 \text{ gm/ml}$]
- Q5. **Statement I** : A one molal solution prepared at 20°C will retain the same molality at 100°C, provided there is no loss of solute or solvent on heating.
Statement II : Molality is independent of temperatures.

02 Mole Concept

- Q6. A mixture of C_3H_8 (g) O_2 having total volume 100 ml in an Eudiometry tube is sparked & it is observed that a contraction of 45 ml is observed what can be the composition of reacting mixture.
- 15 ml C_3H_8 & 85 ml O_2
 - 25 ml C_3H_8 & 75 ml O_2
 - 45 ml C_3H_8 & 55 ml O_2
 - 55 ml C_3H_8 & 45 ml O_2

- Q7. Which has the maximum number of atoms :
- 24 g C
 - 56 g Fe
 - 27 g Al
 - 108 g Ag (108)

- Q8. Match the column:

Column I

- 16 g of CH_4
- 1 g of H_2
- 22 g of CO_2
- 9 g of H_2O

Column II

- $1/2$ mole molecule
- $6.023 \times 10^{23} \times 5$ atoms
- 11.2 litre
- 1.806×10^{23} atoms

- Q9. A 5.2 molal aqueous solution of methyl alcohol, CH_3OH , is supplied. What is the mole fraction of methyl alcohol in the solution
- 0.100
 - 0.190
 - 0.086
 - 0.050
- Q10. A compound H_2X with molar weight of 80 g is dissolved in a solvent having density of 0.4 g mL^{-1} . Assuming no change in volume upon dissolution, the molality of a 3.2 molar solution is



Answer & Solution

ANSWER

Q1	Q2	Q3	Q4	Q5
(c)	(c)	(a)	(b)	(a)
Q6	Q7	Q8	Q9	Q10
(a), (b)	(a)	(A) - Q (B) - P, R (C) - P, R (D) - P	(c)	8

JEE

CHEMISTRY

- ▶ Specially designed eBook for complete JEE syllabus
- ▶ JEE preparation strategy & direction, speedy revision
- ▶ Chapter-wise important Problem-Solving
- ▶ Theory, Formulas & Diagrams to crack JEE
- ▶ Detailed high quality video lectures by experienced faculties
- ▶ JEE full preparation for Class XI & XII



misostudy
connect smart learning

JEE·NEET·AIIMS·CBSE·FOUNDATION
www.misostudy.com

☎ 8929803804 (MON-FRI: 9am-6pm) support@misostudy.com

MISO STUDY INDIA PVT. LTD.
2ND FLOOR 65-A, OMPRO TOWER, KALU SARAI, NEW DELHI, DELHI 110016

Class 12 | Chemistry

02 Solid State

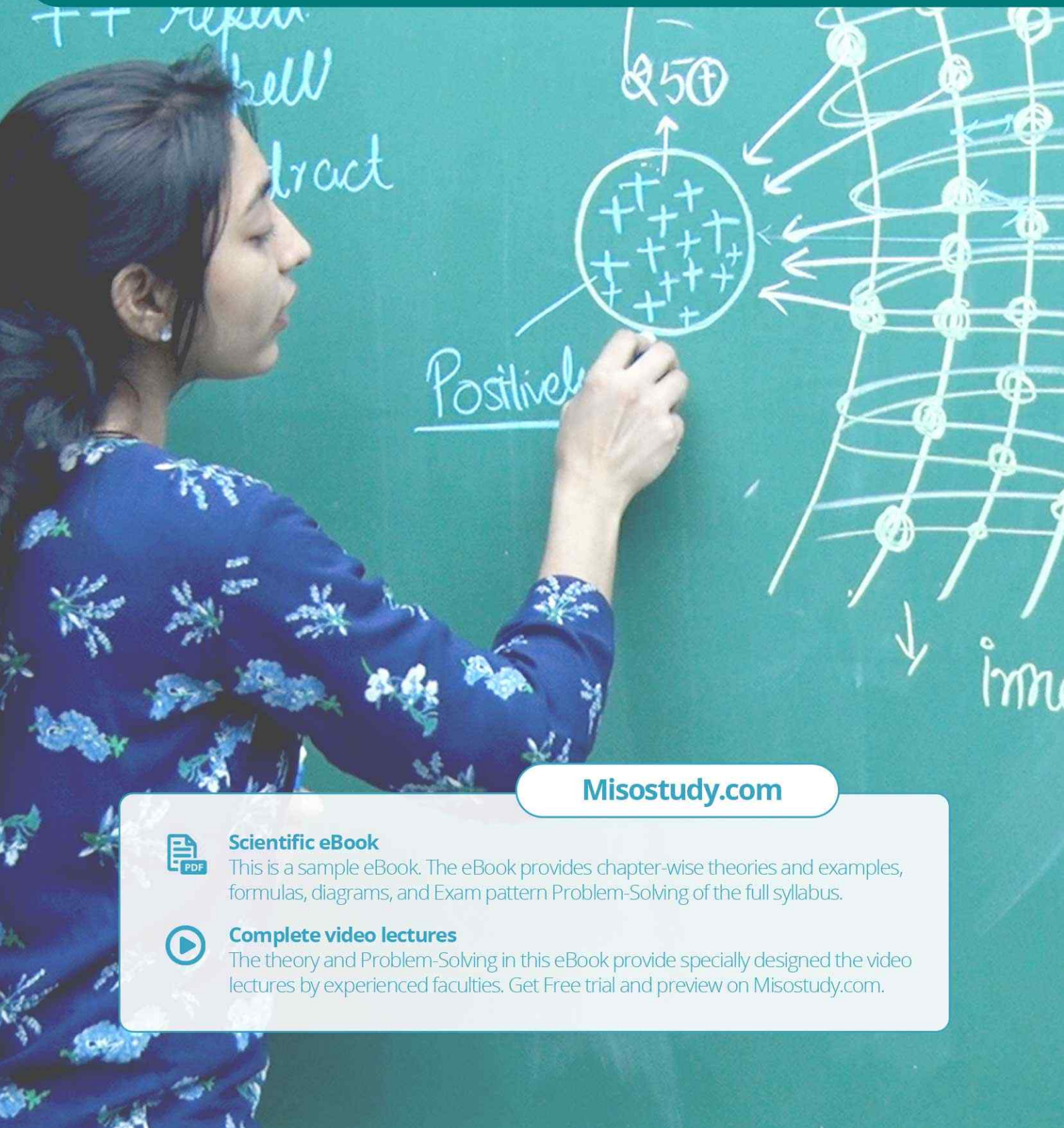

Misostudy.com



Scientific eBook

This is a sample eBook. The eBook provides chapter-wise theories and examples, formulas, diagrams, and Exam pattern Problem-Solving of the full syllabus.



Complete video lectures

The theory and Problem-Solving in this eBook provide specially designed the video lectures by experienced faculties. Get Free trial and preview on Misostudy.com.

01. The Solid State

The solids are characterized by incompressibility, rigidity and mechanical strength. The molecules, atoms or ions in solids are closely packed i.e they are held together by strong forces and can not move about at random. Thus solids have definite volume, shape, low vapour pressure and possess the unique property of being rigid. Such solids are known as true solids e.g. NaCl, KCl, Sugar, Ag, Cu etc. On the other hand the solid which loses shape on long standing, flows under its own weight and is easily distorted by even mild distortion forces are called pseudo solids e.g. glass, plastic etc.

Some solids such as NaCl, Sugar, Sulphur etc. have properties not only of rigidity and incompressibility but also of having typical geometrical forms. These solids are called as crystalline solids. In such solids there is definite arrangement of particles (atoms, ions or molecules) throughout the entire three dimensional network of a crystal. This is named as long-range order. This three dimensional arrangement is called **crystal lattice or space lattice**. Other solids such as glass, rubber, plastics etc. have rigidity and incompressibility to a certain extent but they do not have definite geometrical forms or do not have long range order are known as amorphous solids.

02. Differences Between Crystalline and Amorphous Solids

(i). Characteristic Geometry

In the crystalline solids the particles (atoms, ions, or molecules) are definitely and orderly arranged thus these have characteristic geometry while amorphous solids do not have characteristic geometry.

Melting Points

A crystalline solid has a sharp melting point i.e. it changes into liquid state at a definite temperature. On the contrary an amorphous solid does not have a sharp melting point.

Cooling curve

Amorphous solids show smooth cooling curves while crystalline solids show two breaks in the cooling curve. In the case of crystalline solids two break points 'a' and 'b' appear. These points indicate the beginning and the end of the process of crystallization. In this time interval the temperature remains constant. This is due to the fact that during the crystallization process energy is liberated which compensates for the loss of heat thus the temperature remains constant.

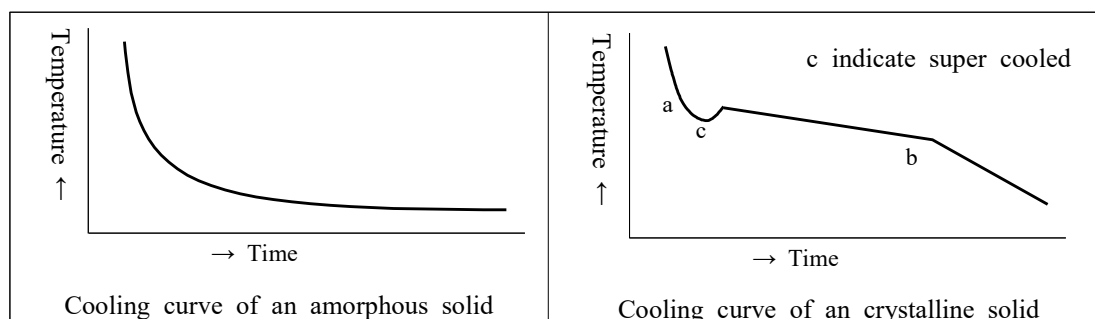

(i). **Isotropy and Anisotropy**

Amorphous solids differ from crystalline solids and resemble liquids in many respects. The properties of amorphous solids, such as electrical conductivity, thermal conductivity, mechanical strength, refractive index, coefficient of thermal expansion etc. are same in all directions. Such solids are known as isotropic. **Gases and liquids are also isotropic.**

On the other hand crystalline solids show these physical properties different in different directions. Therefore crystalline solids are called anisotropic.

03. Crystalline State

“A crystal is a solid composed of atoms (ions or molecules) arranged in an orderly repetitive array”

“**The smallest geometrical position of the crystal which can be used as repetitive unit to build up the whole crystal is called a unit cell.**” The unit cell should have same symmetry elements as the crystal and there should be no gaps between unit cells.

The angle between the two perpendiculars to the two intersecting faces is termed as the interfacial angle which may be same as the angle between the unit cell edges. Goniometer is used to measure the interfacial angle. It is important to note that interfacial angle of a substance remains the same although its shape may be different due to conditions of formation.

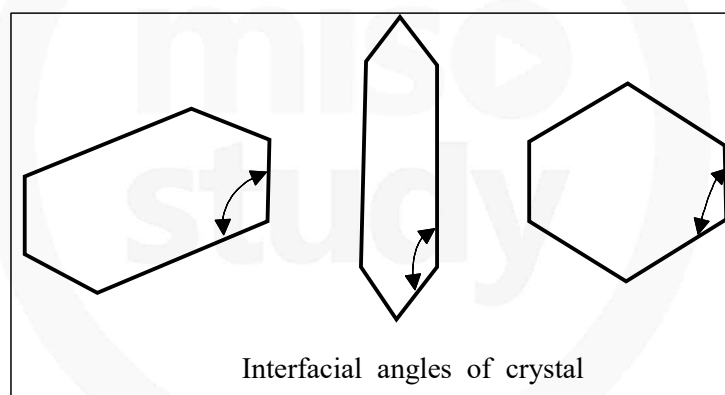

04. Types of the Crystals

Crystals are divided into four important types on the basis of chemical bonding of the constituent atoms.

(i) **Ionic Crystals**

These are formed by a combination of highly electro-positive ions (cations) and highly electronegative ions (anions). Thus strong electrostatic force of attraction acts within the ionic crystals. Therefore, a large amount of energy is required to separate ions from one another.

e.g. NaCl, KF, CsCl etc.

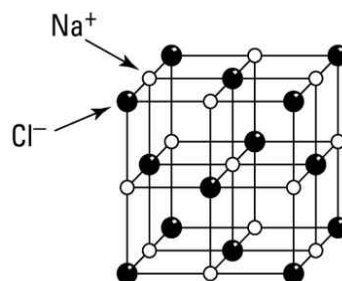

(ii) **Covalent Crystals**

These are formed by sharing of valence electrons between two atoms resulting in the formation of a covalent bond. The covalent bonds extend in two or three dimensions forming a giant interlocking structure called network. Diamond and graphite are the good examples of this type.

(iii) **Molecular Crystals**

In these crystals, molecules occupy the lattice points of the unit cells, except in solidified noble gases in which the units are atoms, where the binding is due to vander Waal's forces and dipole-dipole forces. Since vander Waal's forces are non-directional hence structure of the crystal is determined by geometric consideration only. Solid H_2 , N_2 , O_2 , CO_2 , I_2 , sugar etc. are well known examples of such crystal in which vander Waal's forces are acting.

(iv) **Metallic Crystals**

These are formed by a combination of atoms of electropositive elements. These atoms are bound by metallic bonds. It may be defined as:
The force that binds a metal ion to a number of electrons within its sphere of influences is known as metallic bond.

05. Isomorphism

The occurrence of a given substance in more than one solid crystalline forms have different physical properties is known as polymorphism. This property when occurs in elements is known as allotropy.

Sometimes we come across examples of chemically different solids which crystalline in the crystalline shape. Such substances are said to be Isomorphous (same shape). Their chemical constitutions are very similar and in some cases crystals of one substance may continue to grow when placed in a saturated solution of the other e.g. potash alum and chrome alum crystals have the same shape and can be grown in each other's solutions.

06. SPACE LATTICE/CRYSTALLINE LATTICE/3-D LATTICE

Space lattice is a regular arrangement of lattice points showing how the particles are arranged at different sites in 3D-view.

“The three dimensional distribution of component particles in a crystal can be found by X-ray diffraction of different faces of the crystal. On the basis of the classification of symmetry, the crystals have been divided into seven systems. These can be grouped into 32 classes which in turn can be regrouped into 7 crystal systems. These seven systems with the characteristics of their axes (angles and intercepts) along with some examples of each are given in the following table.

The Seven Crystal System

Name of system		Axes	Angles	Bravais Lattices
1.	Cubic [Isometric]	$a = b = c$	$\alpha = \beta = \gamma = 90^\circ$	Primitive, Face-centred, Body centred = 3
2.	Tetragonal	$a = b \neq c$	$\alpha = \beta = \gamma = 90^\circ$	Primitive, Body centred = 2
3.	Rhombohedral or Trigonal	$a = b = c$	$\alpha = \beta = \gamma \neq 90^\circ$	Primitive = 1
4.	Orthorhombic or Rhombic	$a \neq b \neq c$	$\alpha = \beta = \gamma = 90^\circ$	Primitive, Face-centred, Body centred End centred = 4
5.	Monoclinic	$a \neq b \neq c$	$\alpha = \gamma = 90^\circ$; $\beta \neq 90^\circ$	Primitive, End – centred = 2
6.	Triclinic	$a \neq b \neq c$	$\alpha \neq \beta \neq \gamma \neq 90^\circ$	Primitive = 1
7.	Hexagonal	$a = b \neq c$	$\alpha = \beta = 90^\circ$ $\gamma = 120^\circ$	Primitive = 1 Total = 14

07. Types of Unit Cells

There are four types of unit cells (among the cubic system).

(a) Simple or primitive. Particles are only at the corners of the unit cell.

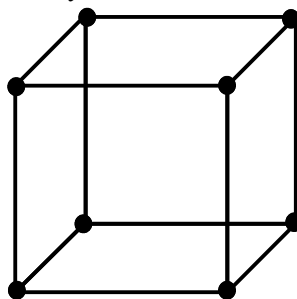

- (b) Face-centred cubic unit cell. A particle is present at the centre of each face of the unit cell.

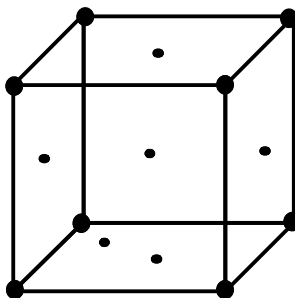

- (c) End-face-centred cubic unit cell. A particle is present at each corner plus particles are present on the end faces of the unit cell.

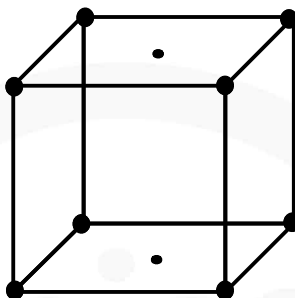

- (d) Body-centred cubic unit cell. In addition to the particles at the corners, there is one particle in the body-centre of the unit cell.

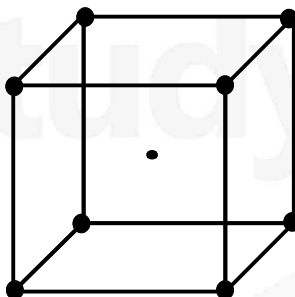

08. Coordination Number

If atoms are represented by spheres, the number of spheres which are touching a particular sphere is called *coordination number* of that sphere. In ionic crystals, the coordination number may be defined as the number of the oppositely charged ions surrounding a particular ion.

09. The number of particles per Unit Cell

- (i) An atom at the corner is shared by 8 unit cells. Therefore, its contribution is = $1/8$.
- (ii) An atom at the face is shared by 2 unit cells. Therefore, its contribution is = $1/2$.
- (iii) An atom present in the body is unshared. Therefore, its contribution is 1.
- (iv) An atom present on the edge is shared by four unit cells. Therefore, its contribution is = $1/4$. Thus, in
- (v) a primitive or simple cubic unit cell, the total number of particles is $1/8 \times 8 = 1$.
- (vi) a face-centred cubic unit cell; the total number of particles is $1/8 \times 8 + 1/2 \times 6 = 4$.
- (vii) a body-centred cubic unit cell, the total number of particles is $1/8 \times 8 + 1 = 2$.

The number of atoms per unit cell are in the same ratio as the stoichiometry of the compound or the ratio of the number of particles A and B present per unit cell gives the formula of the compound formed between A and B.

10. LENGTH OF FACE DIAGONAL AND CUBE DIAGONAL

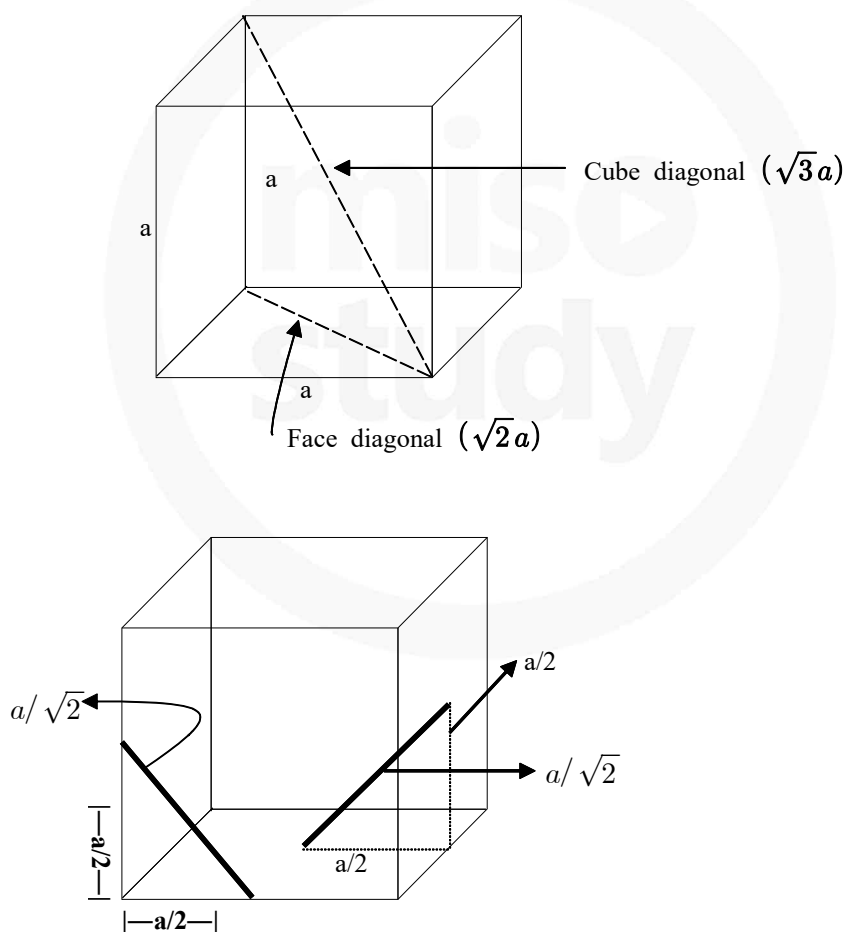

Consider the triangle ABC, with the help of pythagoras theorem
 $AC = \sqrt{AB^2 + BC^2} = \sqrt{a^2 + a^2} = \sqrt{2}a$ (length of face diagonal.)

Consider the triangle DAC, with the help of pythagoras theorem

$$DC = \sqrt{DA^2 + AC^2} = \sqrt{a^2 + (\sqrt{2}a)^2} = \sqrt{3}a \quad (\text{length of cube diagonal})$$

TYPES OF UNIT CELL (BRAVAIS LATTICE)

The distance between successive lattice planes of the same type is called the spacing of planes or inter planar distance between the planes. On the basis of this aspect, the lattices may be divided in following classes.

11. Simple/Primitive/Basic Unit cell

A unit cell having lattice point only at corners called as primitive or simple unit cell. i.e. in this case there is one atom at each of the eight corners of the unit cell considering an atom at one corner as the centre, it will be found that this atom is surrounded by six equidistant neighbours (atoms) and thus the co-ordination number will be six. If 'a' is the side of the unit cell, then the distance between the nearest neighbours shall be equal to 'a'.

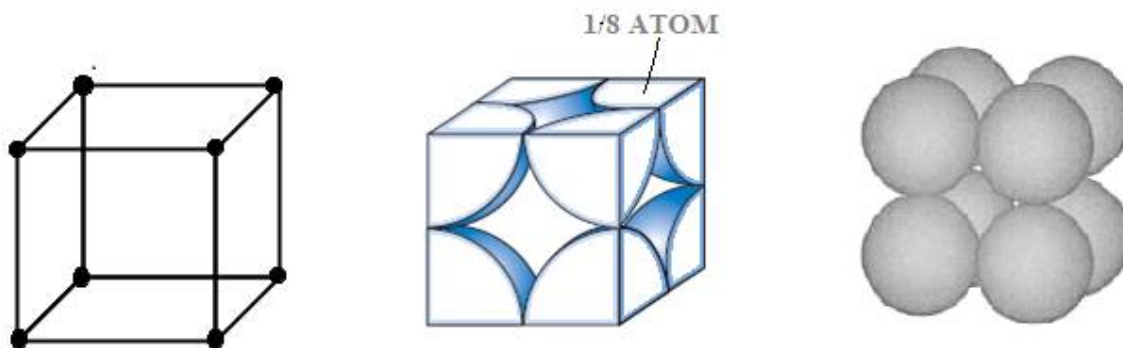

(a) Relationship between edge length 'a' and atomic radius 'r' :

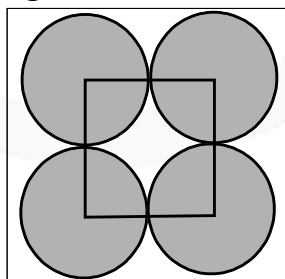

$$a=2r$$

$$\text{i.e. } r = \frac{a}{2} \quad (\text{One face of SCC})$$

(b) Number of atoms present in unit cell

In this case one atom or ion lies at the each corner. Hence simple cubic unit cell contains a total of $\frac{1}{8} \times 8 = 1$ atom or ion/unit cell.

(c) Packing efficiency(P. E.)

$$\text{P.E.} = \frac{\text{Volume occupied by atoms present in unit cell}}{\text{Volume of unit cell}}$$

$$= \frac{n \times \frac{4}{3} \pi r^3}{V} \quad [\because \text{Volume of atom} = \frac{4}{3} \pi r^3]$$

$$\text{For SCC : P.E.} = \frac{1 \times \frac{4}{3} \times \pi \times \left(\frac{a}{2}\right)^3}{a^3} \quad [\because r = \frac{a}{2} \text{ and } V = a^3, n = 1]$$

$$= \frac{\pi}{6} = 0.524 \text{ or } 52.4\%$$

12. Body centred cubic (b.c.c.) cell:

A unit cell having lattice point at the body centre in addition to the lattice point at every corner is called as body centered unit cell.

Here the central atom is surrounded by eight equidistant atoms and hence the co-ordination number is eight. The nearest distance between two atoms will be $\frac{a\sqrt{3}}{2}$

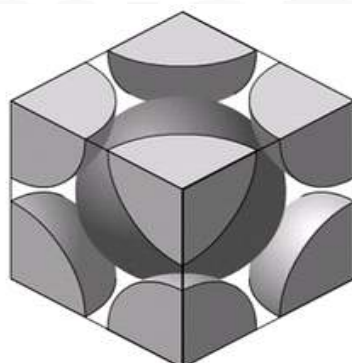

(a) Relationship between edge length 'a' and atomic radius 'r' :

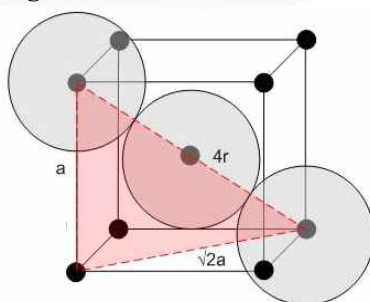

In BCC, along cube diagonal all atoms touches each other and the length of cube diagonal is $\sqrt{3}a$

$$\text{So, } \sqrt{3}a = 4r \quad \text{i.e. } r = \frac{\sqrt{3}a}{4}$$

(b) Number of atom present in unit cell:

$$\left(\frac{1}{8} \times 8\right) + (1 \times 1) = 1 + 1 = 2 \text{ atoms/unit cell}$$

In this case one atom or ion lies at the each corner of the cube. Thus contribution of the 8 corners is $\left(\frac{1}{8} \times 8\right) = 1$, while that of the body centred is 1 in the unit cell. Hence total number of atoms per unit cell is $1 + 1 = 2$ atoms (or ions)

(c) Packing efficiency:

$$\text{P.E.} = \frac{n \times \frac{4}{3} \pi r^3}{V} = \frac{2 \times \frac{4}{3} \times \pi \left(\frac{\sqrt{3}a}{4}\right)^3}{a^3} = \frac{\sqrt{3}\pi}{8} = 0.68 \quad \left[\because n = 2, r = \frac{\sqrt{3}a}{4}, V = a^3 \right]$$

In B.C.C. 68% of total volume is occupied by atom or ions.

13. Face centred cubic (f.c.c.) cell:

A unit cell having lattice point at every face centre in addition to the lattice point at every corner called as face centred unit cell. i.e. in this case there are eight atoms at the eight corners of the unit cell and six atoms at the centre of six faces. Considering an atom at the face centre as origin, it will be found that this face is common to two cubes and there are twelve points surrounding it situated at a distance which is equal to half the face diagonal of the unit cell. Thus the co-ordination number will be twelve and the distance between the two nearest atoms will be $\frac{a}{\sqrt{2}}$.

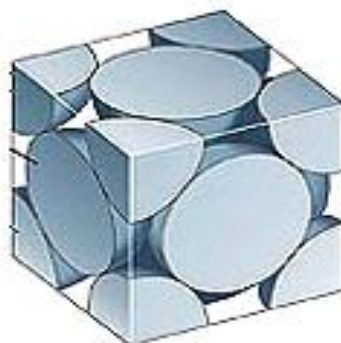
**(a) Relationship between edge length 'a' and atomic radius 'r' :**

In FCC, along the face diagonal all atoms touches each other and the length of face diagonal is $\sqrt{2}a$.

$$\text{So } 4r = \sqrt{2}a \quad \text{i.e. } r = \frac{\sqrt{2}a}{4} = \frac{a}{2\sqrt{2}}, \quad r = \frac{2}{2\sqrt{2}}$$

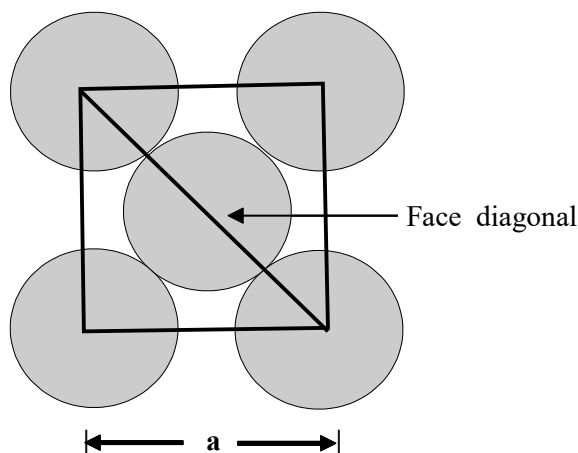

(b) **Number of atoms per unit cell :**

$$\left(\frac{1}{8} \times 8\right) + \left(6 \times \frac{1}{2}\right) = 1 + 3 = 4 \text{ atoms/unit cell}$$

In this case one atom or ion lies at the each corner of the cube and one atom or ion lies at the centre of each face of the cube. It may noted that only $\frac{1}{2}$ of each face sphere lie with in the unit cell and there are six such faces. The total contribution of 8 corners is $\left(\frac{1}{8} \times 8\right) = 1$, while that of 6 face centred atoms is $\left(\frac{1}{2} \times 6\right) = 3$ in the unit cell.

Hence total number of atoms per unit cell is $1+3 = 4$ atoms (or ions).

(c) **Packing efficiency :**

$$\begin{aligned} \text{P.E.} &= \frac{n \times \frac{4}{3} \pi r^3}{V} \quad \left[\because \text{for FCC } n = 4, r = \frac{a}{2\sqrt{2}}, V = a^3 \right] \\ &= \frac{4 \times \frac{4}{3} \pi \times \left(\frac{a}{2\sqrt{2}}\right)^3}{a^3} = \frac{\pi}{3\sqrt{2}} = 0.74 \text{ or } 74\% \end{aligned}$$

i.e. In FCC, 74% of total volume is occupied by atoms.

14. End Centered Unit Cell:

A unit cell having lattice point at the centres of only. one set of opposite faces in addition to the lattice point at every corner called as end centered unit cell.

NOTE This type of Bravais lattice is obtained only in orthorhombic and monoclinic type unit cell.

15. CRYSTAL DENSITY OF THE CRYSTAL

If the length of edge of the unit cell is known we can calculate the density of the crystal as follow: Let length of edge of the unit cell be ℓ .

$$\therefore \text{Volume of the unit cell} = \ell^3 = V \text{ cm}^3$$

$$\text{Density of the unit cell} = \frac{\text{Mass of unit cell}}{\text{Volume of unit cell}}$$

Mass of the unit cell = Number of atoms present in a unit cell \times Mass of one atom = $n \times m$ g

$$\text{But mass of one atom (m)} = \frac{\text{Atomic mass}}{\text{Avogadro Number}} = \frac{M}{N_A}$$

$$\text{Mass of the unit cell} = n \times \frac{M}{N_A} \text{ g}$$

$$\text{Density of the unit cell} = \frac{n \times \frac{M}{N_A}}{V} \text{ gm cm}^{-3}$$

$$\text{Density of the unit cell} = \frac{n \times M}{V \times N_A} \text{ g cm}^{-3} = \text{Crystal density (}\rho\text{)}$$

Example An element (atomic mass = 60) having face centred cubic crystal has a density of 6.23 g cm^{-3} . What is the edge length of the unit cell (Avogadro constant, $N_A = 6.02 \times 10^{23} \text{ mol}^{-1}$).

Solution

$$\text{Density} = \frac{Z \times M}{a^3 \times N_A} \quad Z = 4 \text{ (for fcc)}$$

$$6.23 = \frac{4 \times 60}{a^3 \times 6.022 \times 10^{23}} \quad a^3 = \frac{4 \times 60}{6.23 \times 6.022 \times 10^{23}}$$

$$= 64 \times 10^{-24}$$

$$a = 4 \times 10^{-8} \text{ cm}$$

$$= 4 \times 10^{-10} \text{ m} = 400 \text{ pm.}$$

16. Close packing

It is type of packing with maximum packing fraction & space utilization. The constituent particles of a solid are like hard spheres. These spheres can pack in space in various manner to form a packing. To clearly understand the packing of these spheres, the packing can be categorised as :

- (i) Close packing in one dimension.
- (ii) Close packing in two dimension.
- (iii) Close packing in three dimension.

17. Close packing in one dimension :

In one dimension, only one arrangement of spheres is possible as shown in fig.

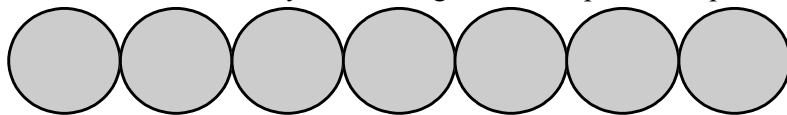

Close packing of spheres in one dimension

Two dimensional packing of spheres :

Two possible types of two dimensional packing are.

- (i) Square close packing in two dimension.
- (ii) Hexagonal close packing in two dimension.

18. Two dimensional square packing of spheres :

When two rows are placed in such a manner, that spheres of one row are placed immediately below of the other, the resulting packing is called two dimensional square close packing.

- (i) Since all the rows are identical the packing is called AAA type packing.
- (ii) Each sphere is touched by four other hence coordination number is four.
- (iii) Of centres of spheres are connected, square cells are formed, hence also called two dimensional square packing.
- (iv) This type of packing is not very effective in terms of utilization of space.

(v) Packing efficiency in 2-D = $\frac{1 \times \pi r^2}{a^2} = \frac{1 \times \pi (a/2)^2}{a^2} = \frac{\pi}{4} = 0.74$.

(vi) Packing efficiency in 3-D = $\frac{1 \times \frac{4}{3} \pi \left(\frac{a}{2}\right)^3}{a^3} = 0.52$ [In 3-D its unit cell is simple cubic]

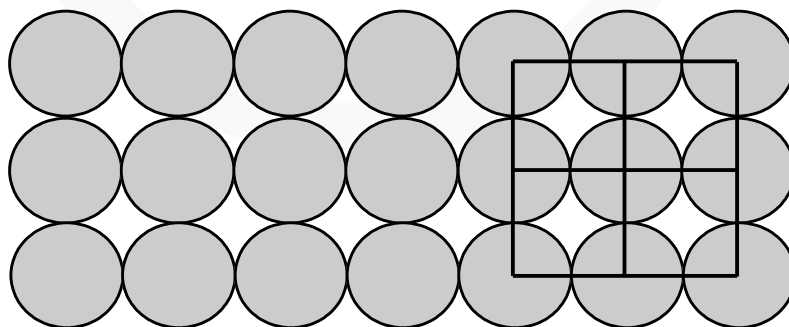

19. Two dimensional hexagonal packing :

If various one dimensional close pack rows are placed in such a way that spheres of top row fits in depression of bottom row spheres, the resulting packing is called two dimensional close packing structure.

- Every third row sphere comes exactly at top of first row sphere, hence the packing is called ABABAB packing.
- If centres are joined, hexagonal unit cells are formed. Hence this is called two dimensional hexagonal close packing.
- This packing is most efficient in utilizing space in two dimensional arrangement.
- Each sphere is touched by six other, hence coordination number is six.

$$(v) \text{ Packing efficiency in 2-D} = \frac{3 \times \pi \left(\frac{a}{2}\right)^2}{\frac{a^3 \sqrt{3}}{4} \times 6} = \frac{\pi}{2\sqrt{3}} = 0.91$$

$$(vi) \text{ Packing efficiency in 3-D} = \frac{3 \times \frac{4}{3} \pi \left(\frac{a}{2}\right)^3}{\frac{a^2 \sqrt{3}}{4} \times 6 \times a} = \frac{\pi}{3\sqrt{3}} = 0.60$$

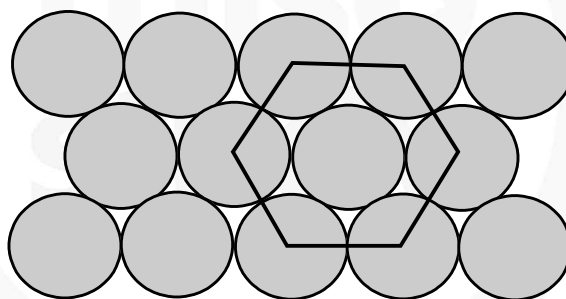

20. Close packing in three dimensions :

When two dimensional packing structure are arranged one above the other, depending upon type of two dimensional arrangement in a layer, and the relative positions of spheres in above or below layer, various types of three dimensional packing results. To define 3-D lattice six lattice parameters are required – 3 edge lengths & 3 angles.

- Simple cubic packing (A A A A)
- Hexagonal close packing (AB AB AB
- Cubic close packing or face centered cubic (...ABC ABC...)

21. Simple cubic packing in three dimension :

The two dimensional square close packed layer are placed, in such a manner that spheres in each layer comes immediately on top of below layer, simple cubic packing results. Important points.

- (i) Atoms all aligned vertically and horizontally in all directions.
- (ii) The unit cell for this packing is simple cubic unit cell.
- (iii) In this packing, only 52% of available space is occupied by atoms.

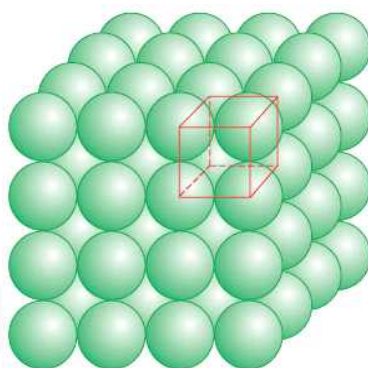

22. Three Dimensionally close packing :

In hexagonal close packing, there are two types of the voids (open space or space left) which are divided into two sets 'b' and 'c' for convenience. The spaces marked 'c' are curved triangular spaces with tips pointing upwards whereas spaces marked 'b' are curved triangular spaces with tips pointing downwards. Now we extend the arrangement of spheres in three dimensions by placing second close packed layer (hexagonal close packing) (B) on the first layer (A). The spheres of second layer may placed either on space denoted by 'b' or 'c'. It may be noted that it is not possible to place sphered on both types of voids (i.e. b and c). Thus half of the voids remain unoccupied by the second layer. The second layer also have voids of the types 'b' and in order to build up the third layer, there are following two ways :

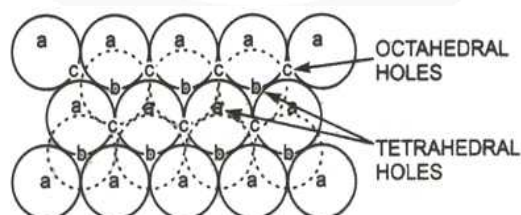

23. Hexagonal close packing (HCP) AB-AB-AB Type :

- (i) In one way, the spheres of the third layer lie on spaces of second layer (B) in such a way that they lie directly above those in the first layer (A). In other words we can say that the layer becomes identical to the first layer. If this arrangement is continued indefinitely in the same order this represented as A B A B A B
This type of arrangement represent hexagonal close packing (hcp) symmetry (or structure), which means that the whole structure has only one 6-fold axis of symmetry i.e. the crystal has same appearance on rotation through an angle of 60° .
- (ii) Every third layer sphere lies on top of first layer sphere. (ABABAB packing)
- (iii) Maximum possible space is occupied by spheres.
- (iv) Each sphere is touched by 12 other spheres in 3D
(6 in one layer, 3 in top layer and 3 in bottom.)
- (v) The unit cell for hexagonal close packing is hexagonal unit cell.
- (vi) For every atom forming hcp there are effectively two tetra voids and one octa void.
That why this generate ABAB AB pattern. One type of void always remain on unoccupied.

Unit cell : $a = 2r = b$; $\gamma = 120^\circ$

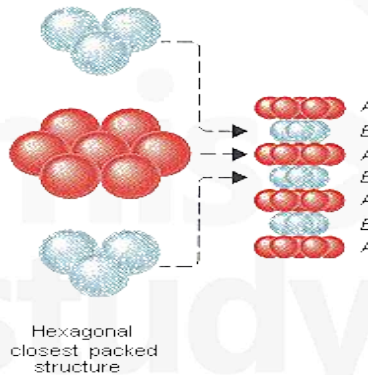

(vii) Packing efficiency of HCP units

Relation between a, b, c and R :

$$a = b = 2R$$

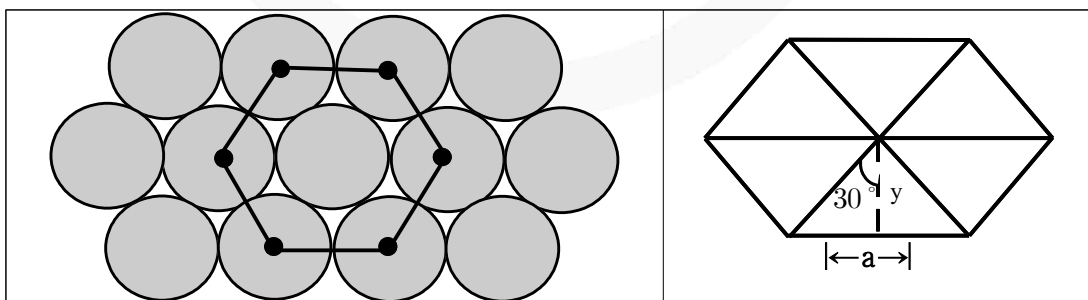

$$\tan 30 = \frac{a}{2 \times y}$$

so

$$y = \frac{a \times \sqrt{3}}{2 \times 1} = \frac{\sqrt{3}}{2} a.$$

$$\text{Area} = 6 \left[\frac{1}{2} a \times \frac{\sqrt{3}}{2} a \right] = \frac{6\sqrt{3}a^2}{4}$$

Calculation of c :

$$\cos 30^\circ = \frac{a}{2 \times x} \quad x = \frac{2a}{2 \times \sqrt{3}} = \frac{a}{\sqrt{3}}$$

Applying pythagoras theorem : $x^2 + h^2 = a^2$

$$\text{So } h^2 = a^2 - x^2 = a^2 - \frac{a^2}{3} = \frac{2}{3} a^2$$

$$h = \frac{2}{\sqrt{3}} a \quad \text{so } c = 2h = 2\sqrt{\frac{2}{3}} a$$

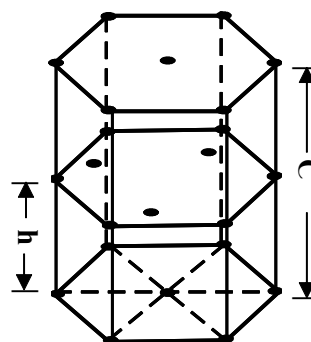

24. ABC – ABC arrangement (Cubic close packing (FCC))

In second way, the spheres of the third layer (C) lie on the second layer (B) in such a way that they lie over the unoccupied spaces 'C' of the first layer(A). If this arrangement is continuous in the same order this is represented as ABC ABC ABC..... This type of arrangement represent cubic close packed (ccp) structure. This structure has 3-fold axes of symmetry which pass through the diagonal of the cube. since in this system, there is a sphere at the centre of each face of the unit cell and hence this structure is also known as face-centred cubic (fcc) structure. It may be noted that in ccp (or fcc) structures each sphere is surrounded by 12 spheres hence the coordination number of each sphere is 12. The spheres occupy 74% of the total volume and 26% of is the empty space in both (hcp and ccp) structure.

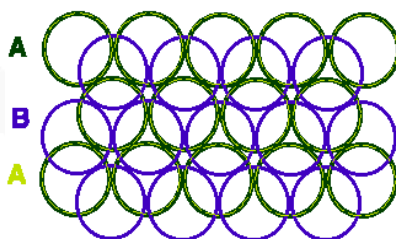

- IIIrd layer will be different from Ist layer as well as IInd layer.
- It is also known as cubical close packing (CCP), unit cell chosen is face centered unit cell (FCC).

Relation between 'a' and 'R' :

$$a \neq 2R \quad \sqrt{2}a = 4R \text{ (Sphere are touching along the face diagonal)}$$

$$\text{Effective no. of atoms per unit cell (Z)} = Z = \frac{1}{8} \times 8 + \frac{1}{2} \times 6 = 4$$

Packing fraction

$$\text{P.F.} = \frac{4 \times \frac{4}{3} \pi R^3}{4 \times 4 \times 4 R^3} \times \sqrt{2} \times 2 = \frac{\pi}{3\sqrt{2}} = 0.74 \text{ (74\%)}$$

Coordination number , (CN) = 12

$$\text{Density (d)} = \frac{Z \times M}{N_A \cdot a^3}$$

INTERSTICES OR VOIDS OR HOLES IN CRYSTALS

It has been shown that the particles are closely packed in the crystals even than there is some empty space left in between the spheres. This is known as interstices (or interstitial site or hole empty space or voids). In three dimensional close packing (CCP & HCP) the interstices are of two types : (i) tetrahedral interstices and (ii) octahedral interstices.

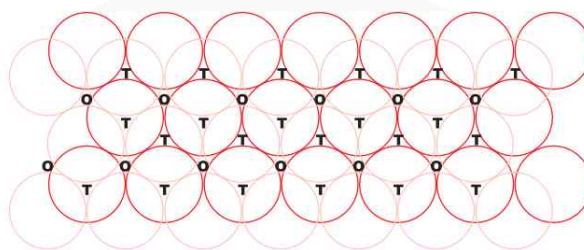
**25. Tetrahedral Interstices :**

We have seen that in hexagonal close packing (hcp) and cubic close packing (ccp) each sphere of second layer touches with three spheres of first layer. Thus they, leave a small space in between which is known as **tetrahedral site or interstices**. or The vacant space between 4 touching spheres is called as tetrahedral void. Since a sphere touches three spheres in the below layer and three spheres in the above layer hence there are two tetrahedral sites associated with one sphere. It may be noted that a tetrahedral site does not mean that the site is tetrahedral in geometry but it means that this site is surrounded by four spheres and the centres of these four spheres lie at the apices of a regular tetrahedron.

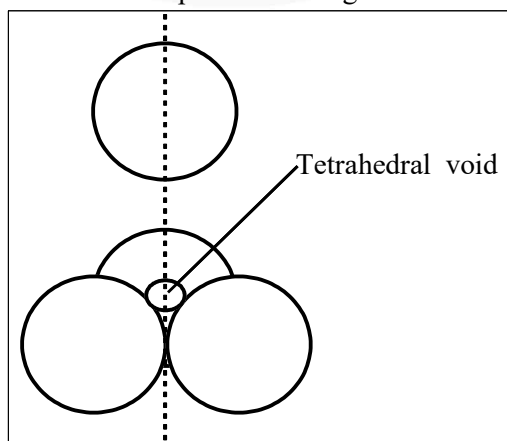

In FCC, one corner and its three face centred atom of faces meeting at that corner form a tetrahedral void.

In FCC, two tetrahedral voids are obtained along one cube diagonal. So in FCC 8 tetrahedral voids are present.

In FCC total number of atoms = 4

In FCC total number of tetrahedral voids = 8

So, we can say that, in 3D close packing 2 tetrahedral voids are attached with one atom.

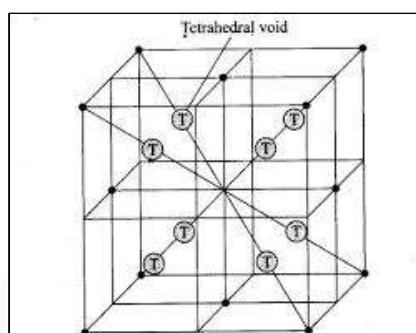

26. Octahedral – Interstices :

Hexagonal close packing (hcp) and cubic close packing (ccp) also form another type of interstices (or site) which is called octahedral site (or interstices). or The vacant space between 6 touching spheres is called as octahedral void.

In the figure two layers of close packed spheres are shown. The spheres of first layer are shown by full circles while that of second layer by dotted circles. Two triangles are drawn by joining the centres of three touching spheres of both the layers.

In FCC, 6 face centres form a octahedral void at body centre.

The apices of these triangles point are in opposite directions. On super imposing these triangles on one another a octahedral site is created. It may be noted that an octahedral site does not mean that the hole is octahedral in shape but it means that this site is surrounded by six nearest neighbour lattice points arranged octahedrally.

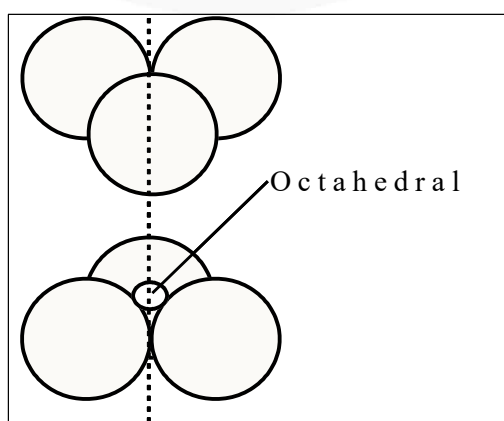

27. Positions of Tetrahedral Voids in an fcc Unit Cell :

The centre of tetrahedral void is located on the centre of body diagonal of each small cube of volume $\left(\frac{a^3}{8}\right)$.

$$\text{Total number of atoms per unit cell} = \frac{1}{2} \times 6 + 8 \times \frac{1}{8} = 4$$

Total number of tetra void = 8

Effective number of tetra void per atom forming close pack = 2.

If a fcc unit cell is divided into eight equal mini-cubes (edge = $a/2$) then centre of tetra voids lies at the centres of each of these mini-cubes. In FCC center of tetra void is at perpendicular distance of $a/4$ from nearest face.

28. Positions of Octahedral Voids in an fcc Unit Cell :

Position of octa void is at mid-point of each edge (total 12 edges in a cube) and at the centre of cube. Each octa void located at mid point of edge contributes $1/4$ to the unit cell. The octa void situated at the centre contributes 1.

In FCC, total number of octahedral voids are

$$(1 \times 1) + \left(12 \times \frac{1}{4}\right) = 1 + 3 = 4$$

(Cube centre) (edge)

In FCC, number of atoms = 4

In FCC, number of octahedral voids = 4

So, we can say that, in any type of close packing one octahedral void is attached with one atom.

29. Limiting Radius Ratios

An ionic crystal contains a large number of cations and anions. Generally cations are smaller in size than anions. The cations are surrounded by anions and they touch each other. These ions are arranged in space in such a way to produce maximum stability. The stability of the ionic crystal may be described in terms of radius ratio i.e. the ratio of the radius of cation (r) to that of anion (R) is (r/R) . The range of (r/R) may be expressed as limiting radius ratio. This value is important to determine the arrangement of the ion in different types of crystals.

Limiting radius ratio for various types of sites

Limiting radius ratio = r/R	Coordination Number of cation	Structural Arrangement (Geometry of voids)	Example
0.155 – 0.225	3	Plane Trigonal	Boron Oxide
0.225 – 0.414	4	Tetrahedral	ZnS, SiO ₂
0.414 – 0.732	4	Square planar	- .
0.414 – 0.732	6	Octahedral	NaCl, MgO ₂
0.732 – 1.000	8	Cubic	CsCl

Example A solid $A^+ B^-$ has NaCl type close packed structure. If the anion has a radius of 250 pm, what should be the ideal radius for the cation ? Can a cation C^+ having a radius of 180 pm be slipped into the tetrahedral site of the crystal $A^+ B^-$? Give reason for your answer.

Solution NaCl = FCC Closed packed structure

$$\frac{r_+(C^+)}{r_-(B^-)} = \frac{180\text{pm}}{250\text{pm}} = 0.72$$

It does not lie in the range 0.225–0.414. Hence, C^+ cannot be slipped into the tetrahedral site.

30. STRUCTURE of NaCl :

The bigger Cl^- forms cubic close packing and small Na^+ occupy positions of all octahedral voids. The radius ratio $\frac{r^+}{r^-}$ lie in the range 0.414 – 0.73.

- (i) Each Na^+ is surrounded by six Cl^- is surrounded by six Na^+ ion. [6:6 coordination]
- (ii) Total no. of Na^+ and Cl^- in each limit cell is 4.
- (iii) Number of formula units of NaCl per unit cell is equal to 4.

(iv) The density of NaCl crystal is given by $d = \left(\frac{4 \times M_{NaCl}}{N_A \times a^3} \right)$

N_A = Avogadro's number ; a = Edge length

The edge length of NaCl unit cell is given by $(2r^+ + 2r^-) \Rightarrow \frac{a}{2} = r^+ + r^-$ (FCC & Octa void)

31. Zinc Blende (Sphalerite) Structure :

Larger anions form ccp arrangement and smaller cations filling half of alternate tetrahedral voids.

- (i) C.N. of $Zn^{2+} = 4$; C.N. of $S^{2-} = 4$ [4 : 4 coordination]
- (ii) Formula units of ZnS per unit cell = 4.

(iii) $d_{ZnS} = \frac{4 \times M_{ZnS}}{N_A \times a^3}$

(iv) $r_{Zn^{2+}} + r_{S^{2-}} = \frac{a\sqrt{3}}{4}$

32. Cesium Halide Structure :

(CsCl) Cl^- at the corners of cube and Cs^+ in the center.

(i) C.N. of Cs^+ = 8 ; C.N. of Cl^- = 8 [8 : 8 coordination]

(ii) Formula units of CsCl per cube = 1

$$\text{(iii) } d_{\text{CsCl}} = \frac{M_{\text{CsCl}}}{N_A \times a^3}$$

$$\text{(iv) } r_{\text{Cs}^+} = r_{\text{Cs}^-} = \frac{a\sqrt{3}}{2} \Rightarrow r^+ + r^- = \frac{a\sqrt{3}}{4} \text{ (FCC \& tetra void)}$$

33. Fluorite Structure :

(CaF_2) Ca^{2+} forming ccp arrangement and F^- filling all tetrahedral voids.

(i) C.N. of F^- = 4 ; C.N. of Ca^{2+} = 8 [8 : 4 coordination]

(ii) Formula units of CaF_2 per unit cell = 4

$$\text{(iii) } d_{\text{CaF}_2} = \frac{4 \times M_{\text{CaF}_2}}{N_A \times a^3}$$

$$\text{(iv) } r_{\text{Ca}^{2+}} + r_{\text{F}^-} = \frac{a\sqrt{3}}{4}$$

34. Imperfections In Solid

Any deviation from the perfectly ordered arrangement constitutes a defect or imperfection. These defects sometimes called thermodynamic defect because the number of these defects depends on the temperature. Crystals may also possess additional defect due to the presence of impurities. Imperfection not only modify the properties of solids but also give rise to new properties.

35. Stoichiometric Defects

Those compounds in which the number of positive and negative ions are exactly in the ratio indicated by their chemical formula are called stoichiometric compounds. eg NaCl (1:1). These solids show following types of defects :

36. Schottky Defect :

This type of defect is created when same number of positive ion and negative ion are missing from their respective positions leaving behind a pair of holes. Schottky defect is more common in ionic compounds with high co-ordination number and where the size of positive and negative ions are almost equal. The presence of large number of schottky defects in crystal results in significant decrease in its density. Eg. NaCl, KCl, CsCl, KBr etc.

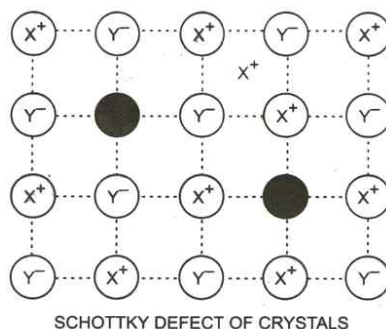

37. Interstitial Defect :

This type of defect is caused due to the presence of ions in the normally vacant interstitial sites in the crystal.

38. Frenkel Defect :

This type of defect is created when an ion leaves its correct lattice site and occupies an interstitial site. Frenkel defects are common in ionic compounds which have low co-ordination number and in which there is large difference in size between positive and negative ions. Eg. ZnS, AgCl, AgBr, Ag etc.

39. Non Stoichiometric Defect Frenkel Defect :

There are many compound in which the ratio of positive and negative ions present in the compound differs from that required by ideal formula of the compound. Such compounds are called Non stoichiometric compounds. eg. VO_x (Where x can vary between 0.6 to 1.3.) In these compounds balance of positive and negative charges is maintained by having extra electrons or extra positive charge. So, these defects are of following types:

40. Metal Excess Defects Due to Anion Vacancies

A compound may have excess metal ion if a negative ion is absent from its lattice site, leaving a hole which is occupied by electron to maintain electrical neutrality. The holes occupied by electrons are called F-centres and are responsible for the colour of the compound. Eg.

- The excess sodium in NaCl makes the crystal appears yellow.
- Excess potassium in KCl makes it violet.
- Excess lithium in LiCl makes it Pink.
- Greater the number of F-centres greater is the intensity of colour. This type of defects are found in crystal which are likely to possess schottky defects.

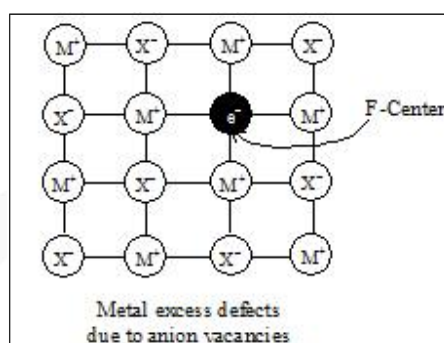

41. Metal Excess Defects Due to Interstitial Cations

It may occur if an extra positive ion is present in an interstitial site, Electrically neutrality is maintained by the presence of an electron in the interstitial site. This type of defects are exhibited by the crystals which are likely to exhibit "Frenkel defects". Eg. Yellow colour of ZnS.

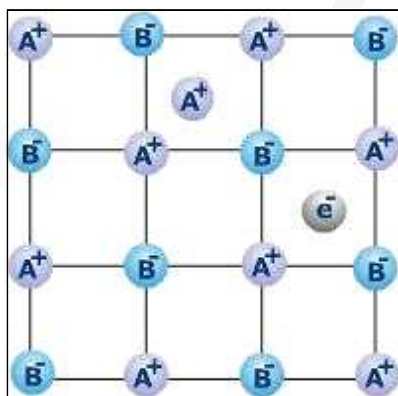

42. Metal Deficiency Due to Cation Vacancies

The non-stoichiometric compound may have metal deficiency due to the absence of a metal ion from its lattice site. The charge is balanced by an adjacent ion having higher positive charge. This type of defects are generally shown by compounds of transition metals.

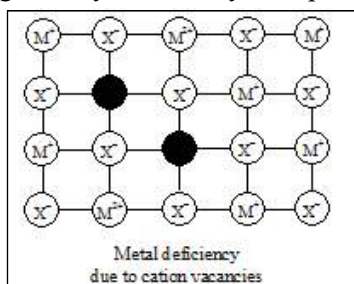

Example Analysis shows that nickel oxide has the formula $\text{Ni}_{0.98}\text{O}$. What fractions of the nickel exist as Ni^{2+} and Ni^{3+} ?

Solution Let Ni^{2+} be x so that Ni^{3+} will be $0.98-x$. Total charge on the compound must be zero so that

$$+ 2x + 3(0.98 - x) - 2 = 0$$

$$2x + 2.94 - 3x - 2 = 0$$

$$-x = -0.94$$

$$\text{or } x = 0.94$$

$$\% \text{ of } \text{Ni}^{2+} = \frac{0.94}{0.98} \times 100 = 96\%$$

$$\% \text{ of } \text{Ni}^{3+} = 4\%$$

JEE Main Pattern Exercise (1)

- Q1. Sodium metal crystallizes in a body centered cubic lattice with a unit cell edge of 4.29\AA . The radius of sodium atom is approximately.
- 1.86\AA
 - 3.22\AA
 - 5.72\AA
 - 0.93\AA
- Q2. CsCl crystallizes in body centred cubic lattice. If 'a' its edge length, then which of the following expressions is correct?
- $r_{\text{Cs}^+} + r_{\text{Cl}^-} = 3a$
 - $r_{\text{Cs}^+} + r_{\text{Cl}^-} = \frac{3a}{2}$
 - $r_{\text{Cs}^+} + r_{\text{Cl}^-} = \frac{\sqrt{3}}{2}a$
 - $r_{\text{Cs}^+} + r_{\text{Cl}^-} = \sqrt{3}a$
- Q3. Experimentally it was found that a metal oxide has formula $M_{0.98}\text{O}$. Metal M , present as M^{2+} and M^{3+} in its oxide. Fraction of the metal which exists as M^{3+} would be
- 7.01%
 - 4.08%
 - 6.05%
 - 5.08%
- Q4. Which of the following exists as covalent crystals in the solid state?
- Iodine
 - Silicon
 - Sulphur
 - Phosphorus
- Q5. In FCC unit cell, what fraction of edge is not covered by atoms?
- 0.134
 - 0.24
 - 0.293
 - None of these

Q6. The packing efficiency of two-dimensional square unit cell shown below is

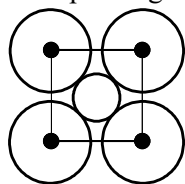

- (a) 39.27% (c) 74.05%
(b) 68.02% (d) 78.54%

Q7. A substance A_xB_y crystallizes in a face centred cubic (fcc) lattice in which atoms A occupy each corner of the cube and atoms B occupy the centres of each face of the cube. Identify the correct composition of the substance A_xB_y

- (a) AB_3
(b) A_4B_3
(c) A_3B
(d) composition cannot be specified

Q8. The coordination number of a metal crystallizing in a hexagonal close-packed structure is

- (a) 12
(b) 4
(c) 8
(d) 6

Q9. Which of the following fcc structure contains cations in alternate tetrahedral voids?

- (a) NaCl
(b) ZnS
(c) Na_2O
(d) CaF_2

Q10. A solid is formed and it has three types of atoms X, Y, Z. X forms a FCC lattice with Y atoms occupying all the tetrahedral voids and Z atoms occupying half the octahedral voids. The formula of the solid is:

- (a) XY_2Z
(b) XY_2Z_4
(c) X_2Y_4Z
(d) X_4YZ_2



Answer & Solution

ANSWER

Q1	Q2	Q3	Q4	Q5
(a)	(c)	(b)	(b)	(c)
Q6	Q7	Q8	Q9	Q10
(d)	(a)	(a)	(b)	(c)

miso
study

JEE Advanced Pattern Exercise (1)

- Q1. The correct statement(s) regarding defects in solids is/are
- Frenkel defect is usually favoured by a very small difference in the sizes of cation and anion
 - Frenkel defect is a dislocation defect
 - Trapping of an electron in the lattice leads to the formation of F-centre
 - Schottky defects have no effect on the physical properties of solids

Q2. **Assertion and Reason**

- Statement I is correct Statement II is correct Statement II is the correct explanation of Statement I
- Statement I is correct Statement II is correct Statement II is not the correct explanation of Statement I
- Statement I is correct Statement II is incorrect
- Statement I is incorrect Statement II is correct

Statement I

In any ionic solid (MX) with Schottky defects, the number of positive and negative ions are same.

Statement II

Equal numbers of cation and anion vacancies are present.

In hexagonal systems of crystals, a frequently encountered arrangement of atoms is described as a hexagonal prism. Here, the top of bottom of the cell are regular hexagons and three atoms are sandwiched in between them. A space-filling model of this structure, called hexagonal close-packed (hcp), is constituted of a sphere on a flat surface surrounded in the same plane by six identical spheres as closely as possible. Three spheres are then placed over the first layer so that they touch each other and represent the second layer. Each one of these three spheres touches three spheres of the bottom layer. Finally, the second layer is covered with a third layer that is identical to the bottom layer in relative position.

- Q3. The number of atoms in one of this hcp unit cell is

- 4
- 6
- 12
- 17

- Q4. The volume of this hcp unit cell is

- $24\sqrt{2}r^3$
- $16\sqrt{2}r^3$
- $12\sqrt{2}r^3$
- $\frac{64r^3}{3\sqrt{3}}$

Q5. The empty space in this hcp unit cell is

- (a) 74%
- (b) 47.6
- (c) 32%
- (d) 26%

Q6. Match the crystal system/unit cells mentioned in Column I with their characteristic features mentioned in Column II.

Column I		Column II	
A.	Simple cubic and face centred cubic	p.	have these cell parameters $a=b=c$ and $\alpha = \beta = \gamma = 90^\circ$
B.	Cubic and rhombohedral	q.	are two crystal systems
C.	Cubic and tetragonal	r.	have only two crystallographic angles of 90°
D.	Hexagonal and monoclinic	s.	belong to same crystal system

Q7. In FCC unit cell, what fraction of edge is not covered by atoms?

- (a) 0.134
- (b) 0.24
- (c) 0.293
- (d) None of these

Q8. Silver (atomic weight = 108 g mol^{-1}) has a density of 10.5 g cm^{-3} . The number of silver atoms on a surface of area 10^{-12} m^2 can be expressed in scientific notation as $y \times 10^x$. The value of x is

Q9. Which of the following Statement (s) is/are correct?

- (a) The coordination number of each type of ion in CsCl crystal is 8
- (b) A metal that crystallizes in bcc structure has a coordination number of 12
- (c) A unit cell of an ionic crystal shares some of its ions with other unit cells
- (d) The length of the unit cell in NaCl is 552 pm. ($r_{\text{Na}^+} = 95 \text{ pm}$; $r_{\text{Cl}^-} = 181 \text{ pm}$)

Q10. The packing efficiency of two-dimensional square unit cell shown below is

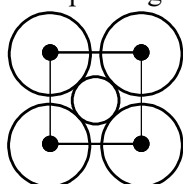

- (a) 39.27%
- (b) 68.02%
- (c) 74.05%
- (d) 78.54%



Answer & Solution

ANSWER

Q1	Q2	Q3	Q4	Q5
(b), (c)	(a)	(b)	(a)	(d)
Q6	Q7	Q8	Q9	Q10
(A) - p , s (B) - q (C) - q (D) - q , r	(c)	7	(a), (c), (d)	(d)